



# PRINCIPLES AND APPLICATIONS OF OPTICAL TWEEZERS

*Dr. Filippo Pierini*

*IPPT PAN Department of Mechanics and Physics of Fluids (ZMiFP)*

# ***OUTLINE***

*1) Introduction*

*2) Principles of Optical Tweezers Trapping Forces*

*3) The Optical Tweezers Set up and Experimental Methods*

*4) Applications*

# History

- P. Apianus (1495-1552): considered solar radiation responsible of comet tail
- J. Kepler (1571-1630): noticed comet's tail always points away from the sun, because of the sun's radiation pressure.
- J. Maxwell (1831-1879): existence of the light pressure was demostred
- P. N. Lebedev (1866-1912): measured the light pressure
- A. Einstein (1879-1955): confirmed that photons possess its own momentum
- A. Compton (1892-1962:) showed the existence of the light momentum

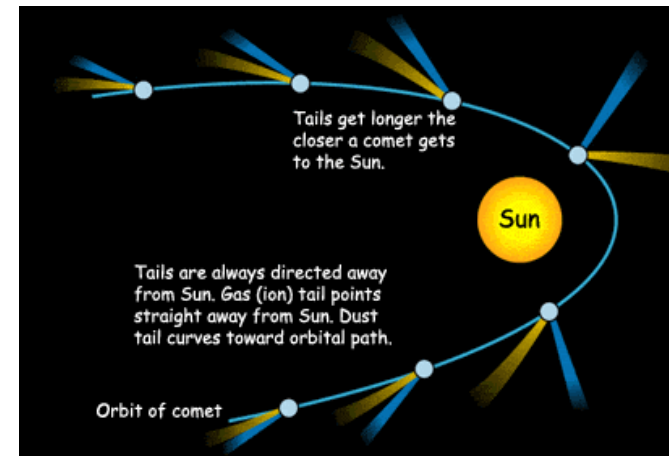
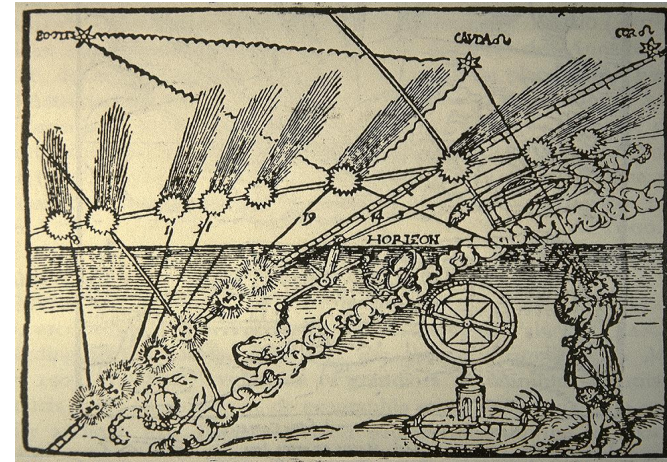

# History

## LASER

*“Stimulated Optical Radiation in Ruby”*  
T. Maiman, *Nature* 187, 493 – 494  
6 August 1960



## NANOTECHNOLOGY

*“There’s plenty of room at the bottom”*  
Lecture given by R. Feynman at Caltech  
29 December 1959

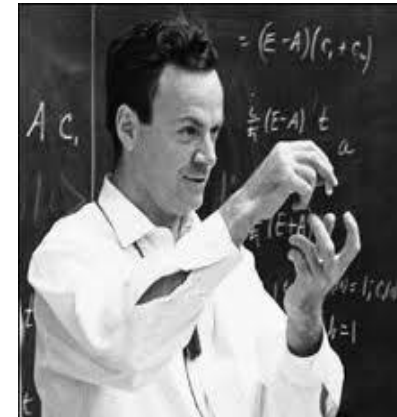

# History

- In 1970 A. Ashkin proved that light can grab and release nanometer particles by its momentum.

- In 1986, A. Ashkin trap 10nm diameter particles

-In 1987, A. Ashkin showed the damage-free manipulation on cell using an infrared laser

*Ashkin, Acceleration and trapping of particles by radiation pressure, Phys. Rev. Lett. 24, 156 (1970)*

*Ashkin, Trapping of atoms by resonance radiation pressure, Phys. Rev. Lett. 40, 729 (1978)*

*Ashkin, Optical trapping and manipulation of virus and bacteria, Science 235, 1517 (1987)*

*Ashkin, Optical trapping and manipulation of single living cells using infra-red laser beams, Phys. Chem 93, 254 (1989)*

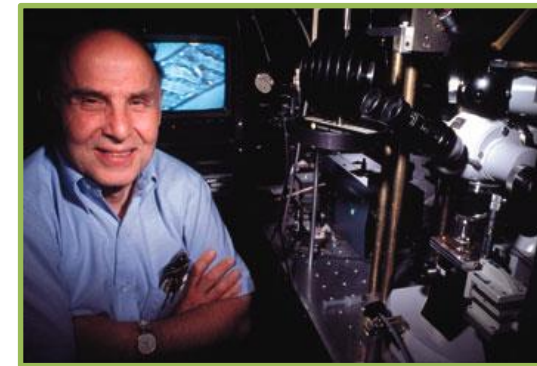

**Arthur Ashkin**

# What are Optical Tweezers?

*Optical tweezers can trap and manipulate nanometer and micrometer-sized particles*

*Optical Tweezers - one of the techniques, which use a highly focused beam to control and hold microscopic particles*

*In Optical Tweezers a tightly focused laser produces a force great enough to trap particles.*



*K.C. Neuman and S. M. Block, Optical Trapping, Rev. Sci. Inst., (2004)*

*J. E. Molloy and M. J. Padgett, Lights, Action: Optical Tweezers, Cont. Phys., (2002)*

# ***What are Optical Tweezers?***

*Optical trap: the most versatile single-molecule manipulation technique*

*Used to exert forces on particles ranging in size from nanometers to micrometers*

*Measuring the three-dimensional displacement of the trapped particle with sub-nanometer accuracy and sub-millisecond time resolution*

*Suitable for measuring force and motion*

# The scales



	Optical tweezers
Temporal resolution (s)	$10^{-4}$
Stiffness ( $\text{pN nm}^{-1}$ )	0.005–1
Force range (pN)	0.1–100
Displacement range (nm)	0.01–10
Probe size ( $\mu\text{m}$ )	0.25–5
Typical applications	3D manipulation Tethered assay Interaction assay



# Conditions of OT – $r \gg \lambda$

Conditions for Mie scattering when the particle radius  $a$  is larger than the wavelength of the light  $\lambda$ .

We can use a ray optics treatment and look at the transfer of momentum

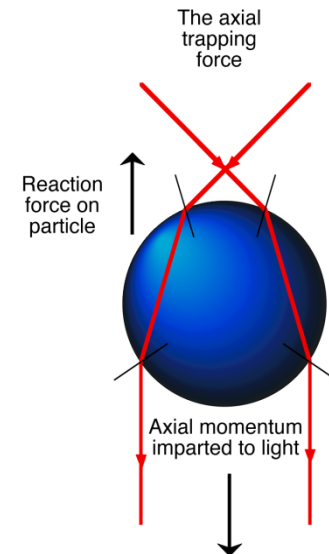
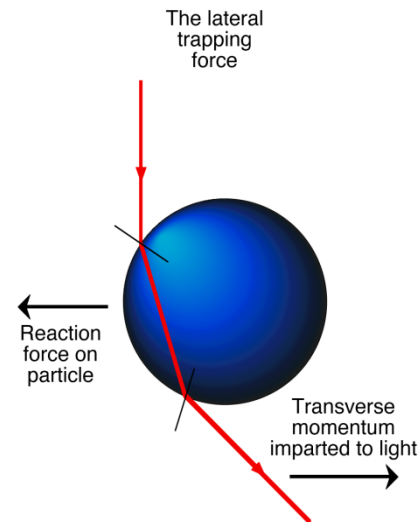
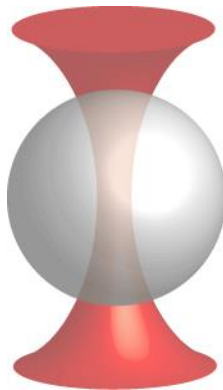

# The Ray Optics Approach

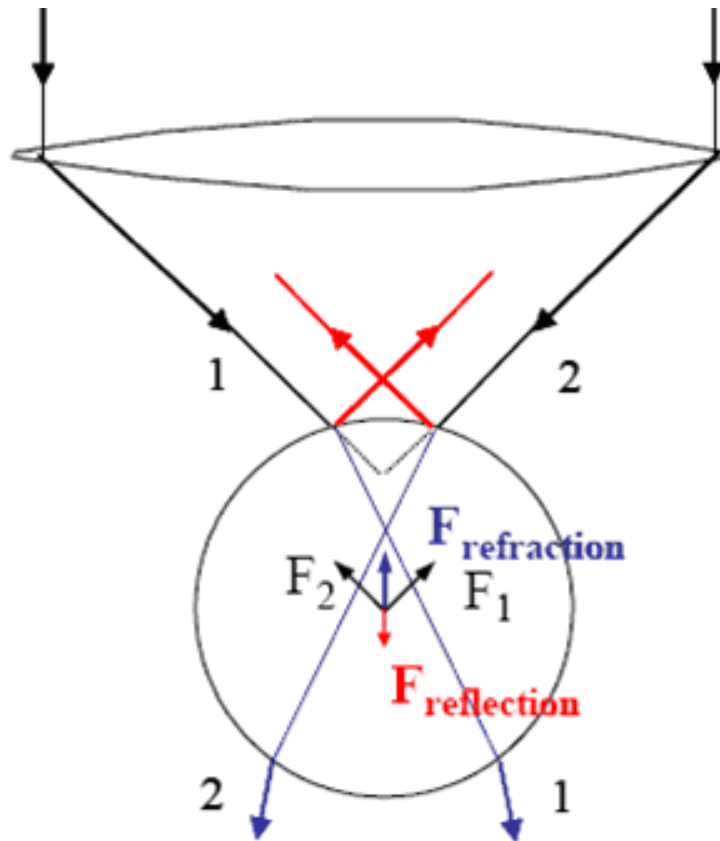

A) The reflected photons create a scattering force.

B) The refracted photons create a restoring force towards the focus of the beam.

$$p = h/\lambda$$

$$F = dp/dt$$

# Gaussian beam profile intensity

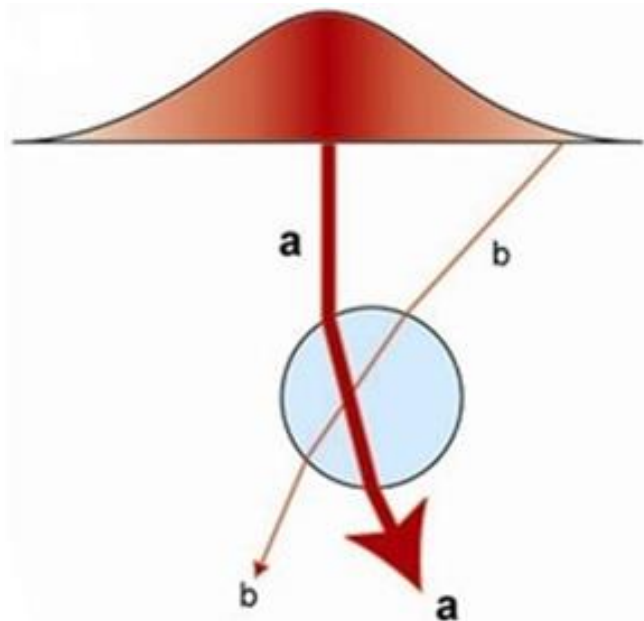

*The force from a single beam gradient optical trap with Gaussian intensity profile. The central ray, a, is of higher intensity than ray b*

# Bead moves to left or right

Newton's third law – for every action there is an equal and opposite reaction

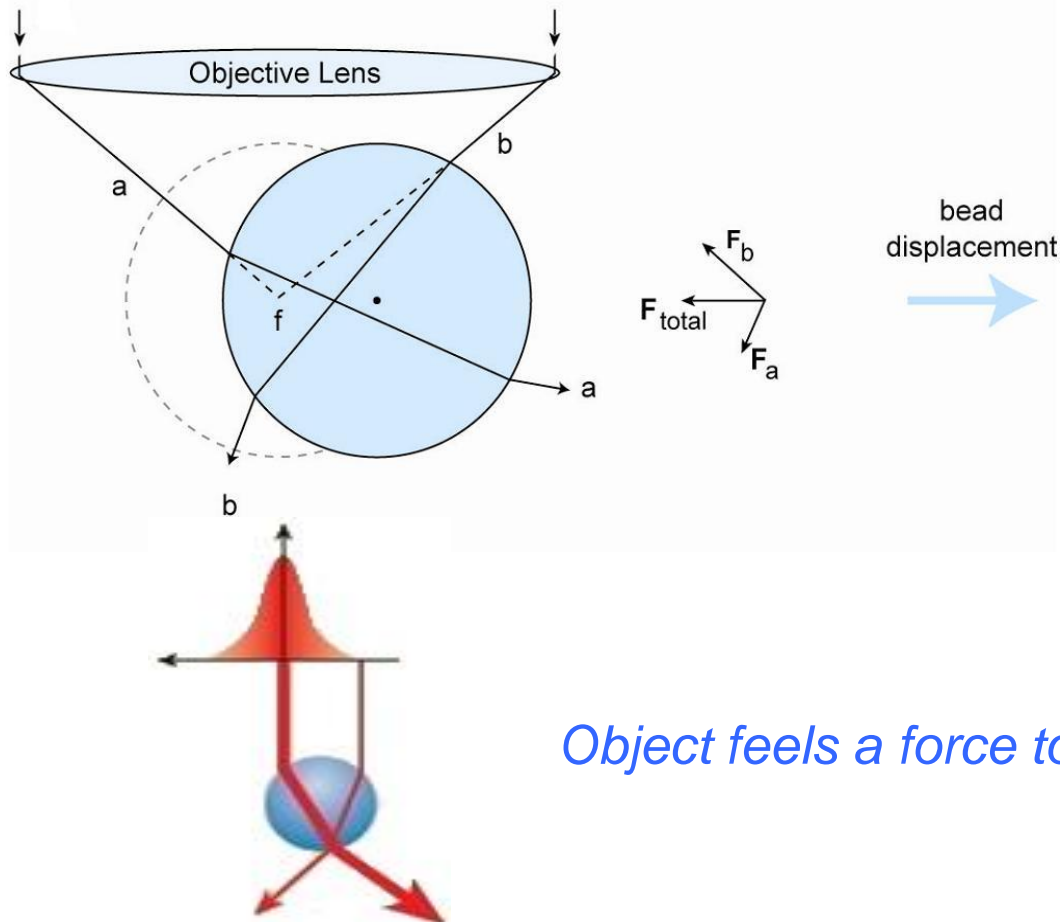

$F_a$  and  $F_b$  represent the forces imparted to the bead by rays a and b

$F_{total}$  is the sum of these two vectors and points to the left.

Object feels a force toward brighter light

# Bead moves forward or backward

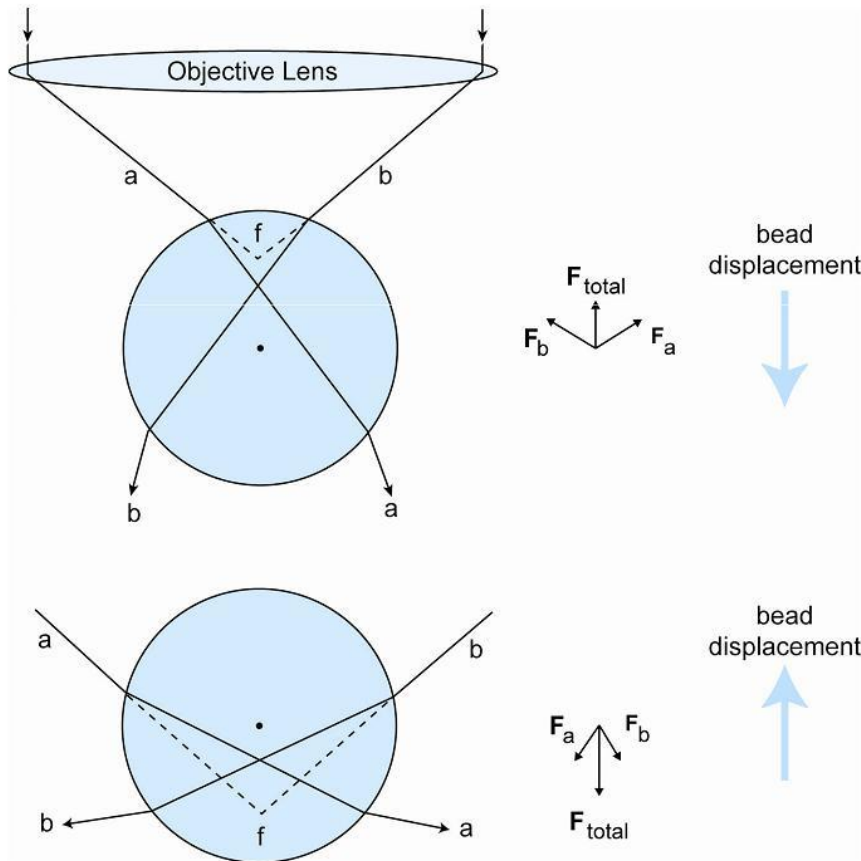

Object feels a force toward focus  
Force  $\sim$  gradient intensity

When the bead is displaced **below** the laser focus, the deflected rays *a* and *b* are more convergent, and resulting force points upward

When the bead is displaced **above** the laser focus, the deflected rays *a* and *b* are more divergent, and the resulting force points downward

# Description

*A laser beam is expanded and collimated. This collimated beam is directed through a microscope objective into channel. Spheres with a higher index of refraction than the medium in will be trapped at the focus of the beam*

# The Basic OT Set up

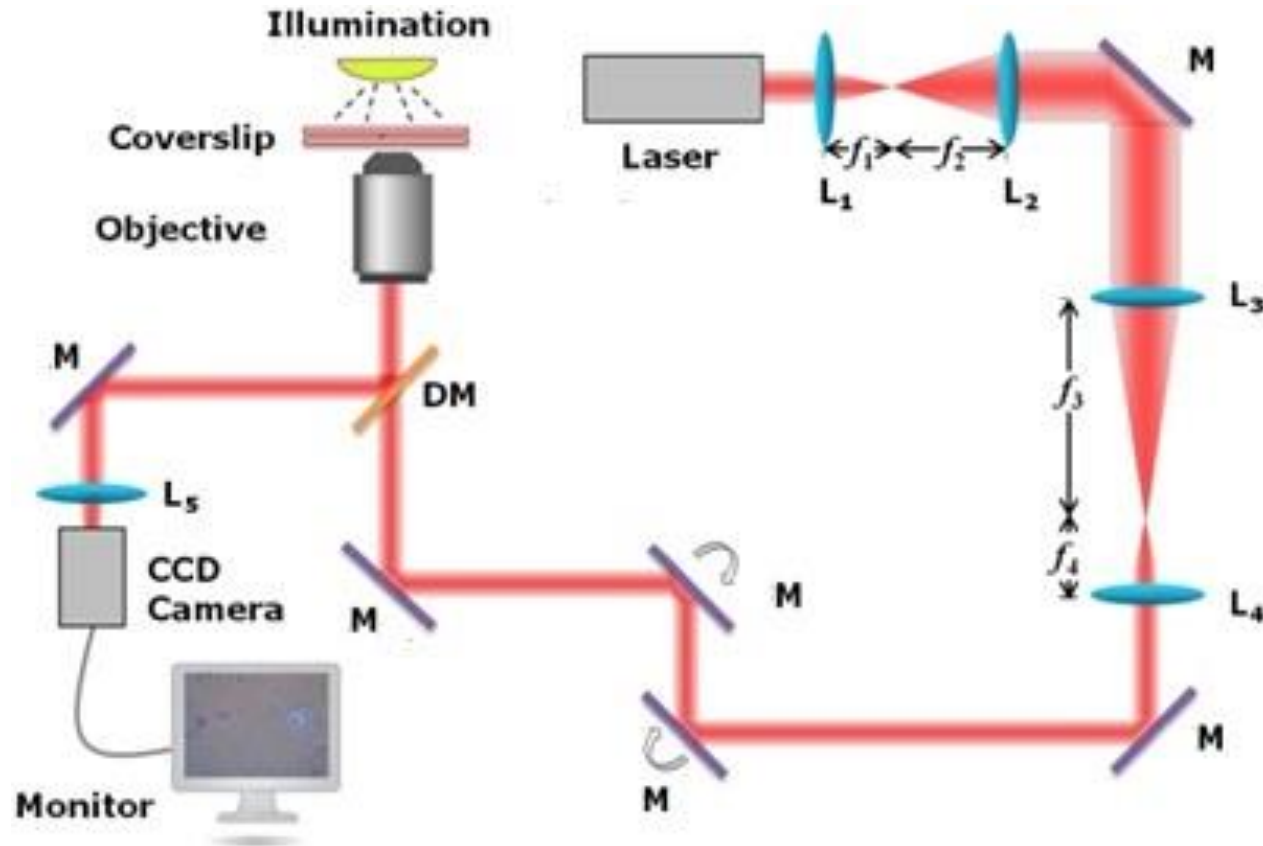

# Technical requirements

*Trapping lasers: Gaussian output intensity profile to achieve the smallest focal spot producing the largest optical gradient*

*A trapping laser with superior pointing and power stability: fluctuations in beam pointing increase noise.*

*Trapping lasers: Near infrared wavelengths (800–1,100 nm) minimize optically induced damage in biological specimens. Diode-pumped neodymium-doped yttrium aluminum garnet (Nd:YAG) with a wavelength of 1,064 nm*

*Focused laser beam to a diffraction-limited spot with a high numerical aperture (NA) microscope objective: Light-gathering ability and resolution*

*The NA of the trapping objective: at least 1.2 to achieve the steep focus needed to create a stable optical trap.*



# Numerical Aperture (NA)

NA: Dimensionless number that characterizes the range of angles over which the system can accept or emit light. Lenses with larger numerical apertures collect more light and generally provide a brighter image

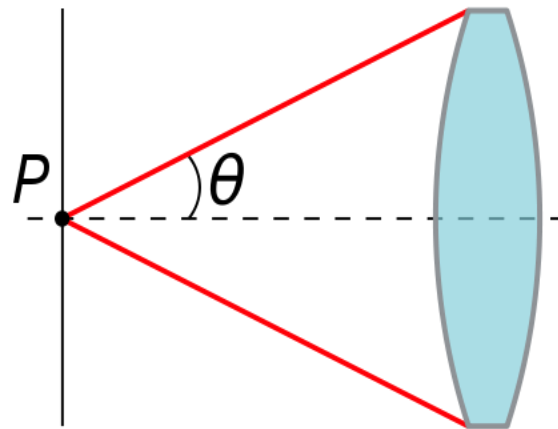

$$NA = n \sin \theta$$

- $n$  is the index of refraction of the medium in which the lens is working (1.0 for air, 1.33 for pure water, and up to 1.56 for oils)
- $\theta$  is the half-angle of the maximum cone of light that can enter or exit the lens

# Some background optics

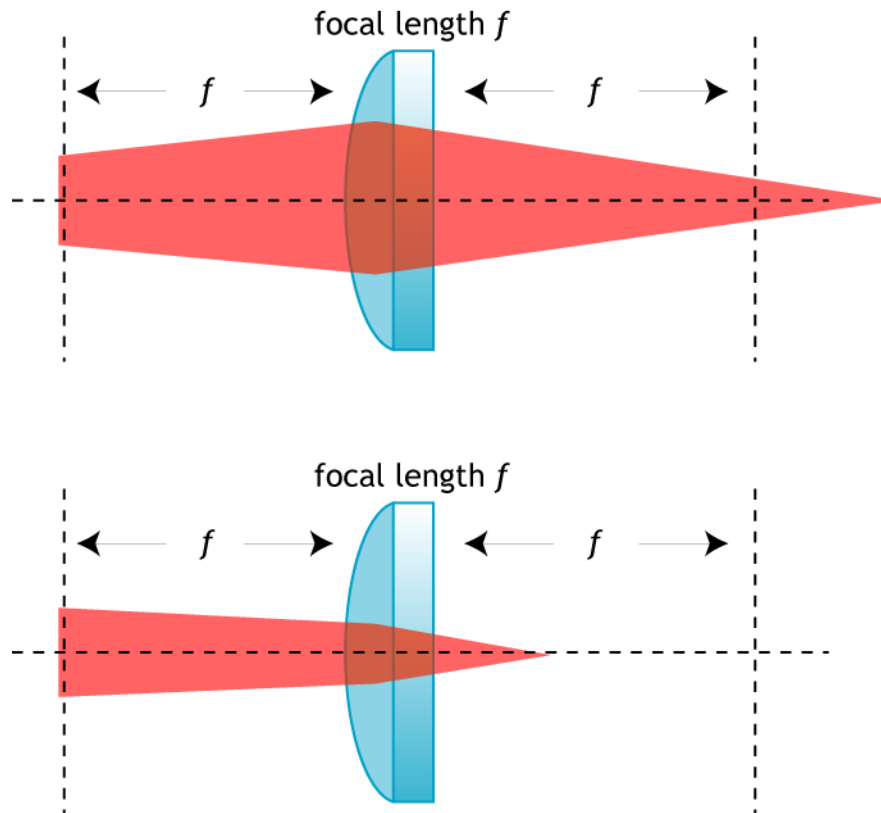

*If the beam is not collimated there is a shift in the axial position of the focus*

# Some background optics

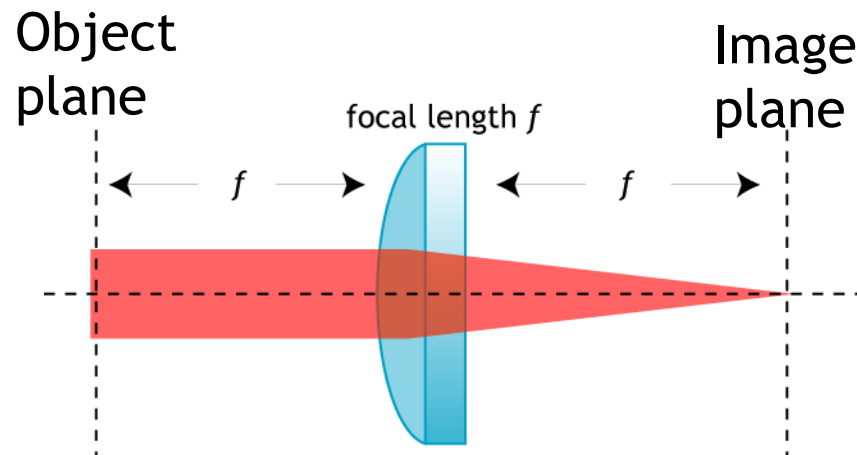

*Collimated light is brought to a focus a distance  $f$ , from a lens of focal length  $f$*

*An angular shift in the object plane results in a lateral shift in the image plane*

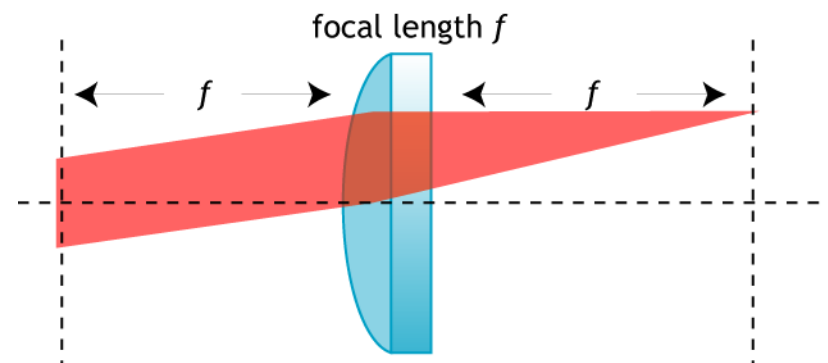

# Moving objects around

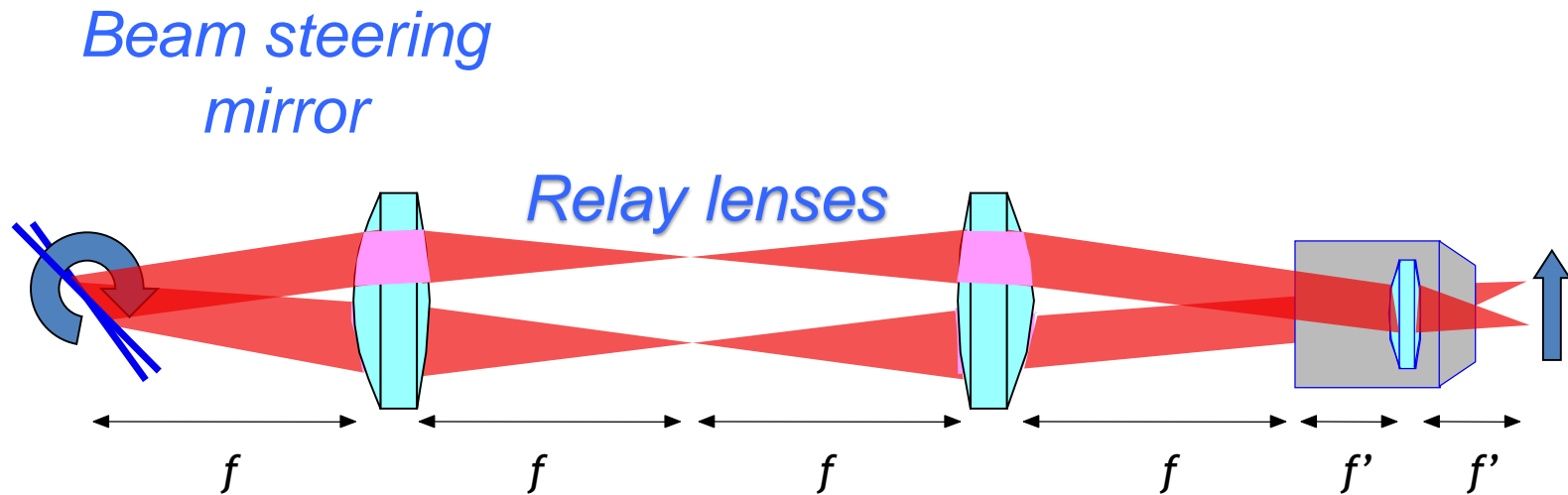

*Angular deflection at mirror gives lateral shift of trap*

# The Scales

*Tightly focused laser beam*

*Particles with higher refraction index than of surrounding medium*

*Wavelength of the laser  $\sim$  size of trapped object ( $d=10\text{nm}$  to  $10\ \mu\text{m}$ )*

*Powerful laser beam: 10-1000mW*

*Microscope objective:  $NA \geq 1$*

*Particle movement: 20-30 $\mu\text{m}$  per sec*

*Force strength: 0,1-100pN*

# Team/Resources

## Our team:

*Supervisor: Prof. Tomasz A. Kowalewski*

*People: Filippo Pierini, Krzysztof Zembrzycki, Sylwia Pawłowska and Patryk Hejduk*

*Equipment: 1064-633-532 nm laser, microscope objective (NA= 1,3), CCD camera, quadrant photodiode, beam expander, dichroic mirrors, beam splitters, polarizer beam splitters, mirrors, filters, shutters, photodiodes, white light source, x-y-z piezostage and optical table*

*Material: Fluorescent polystyrene particles, Fluorescent Carboxylate-Modified polystyrene particles, gold nanoparticles*

# IPPT Optical Tweezers

LS white light source  
 DM dichroic mirror  
 M mirror  
 IRF infrared filter  
 P power regulator  
 BE beam expander  
 QPD quadrant photo diode  
 BS beam splitter  
 PBS polarizer beam splitter  
 PS piezo stage

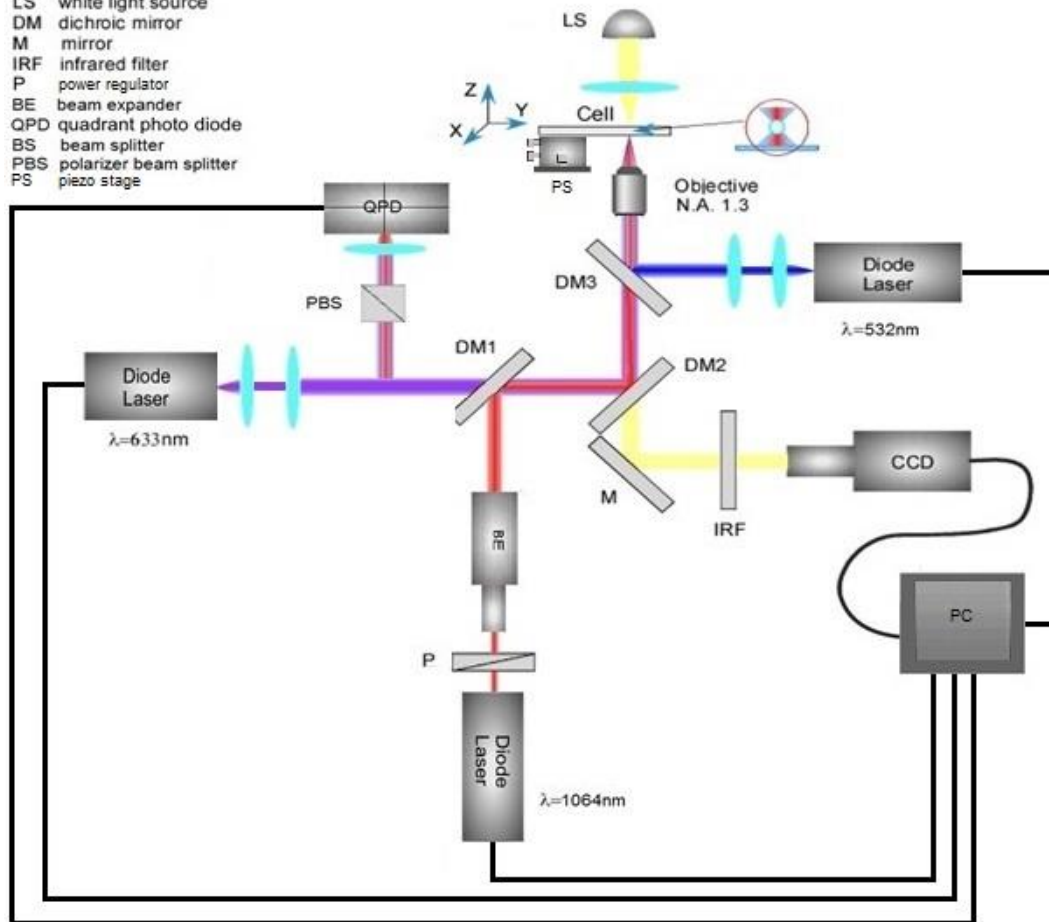

# IPPT Optical Tweezers

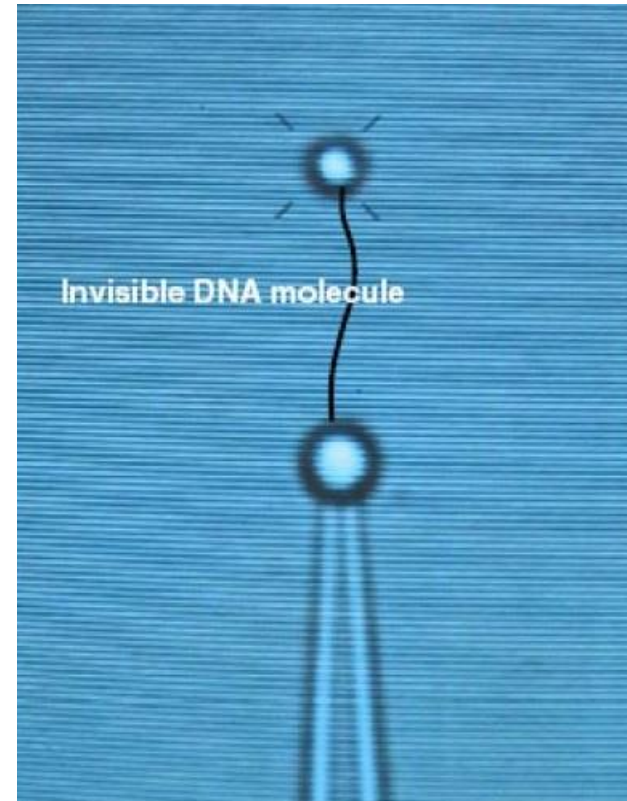
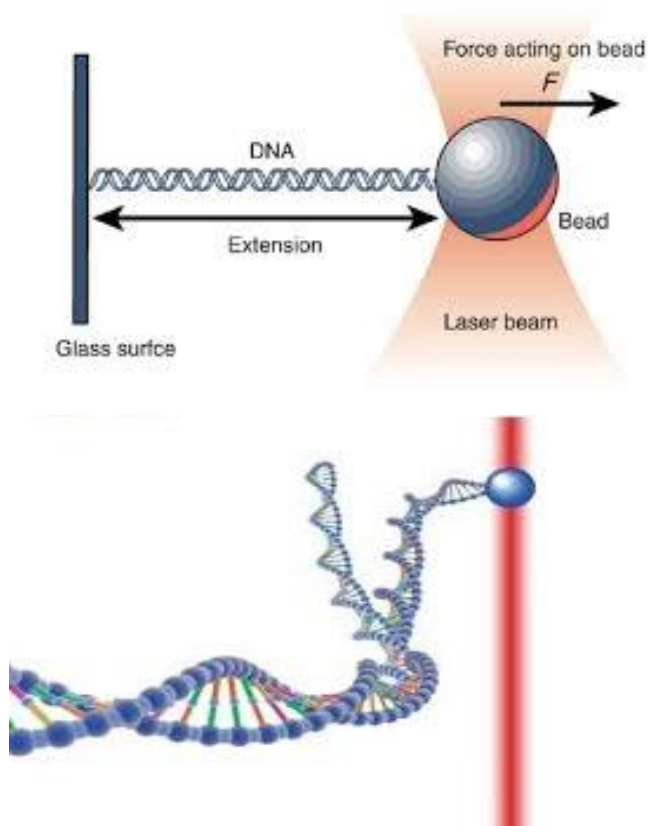

*The aim of the project is to elucidate physical phenomena responsible for folding-unfolding mechanisms of long molecular objects*



# Optical Tweezers Calibration

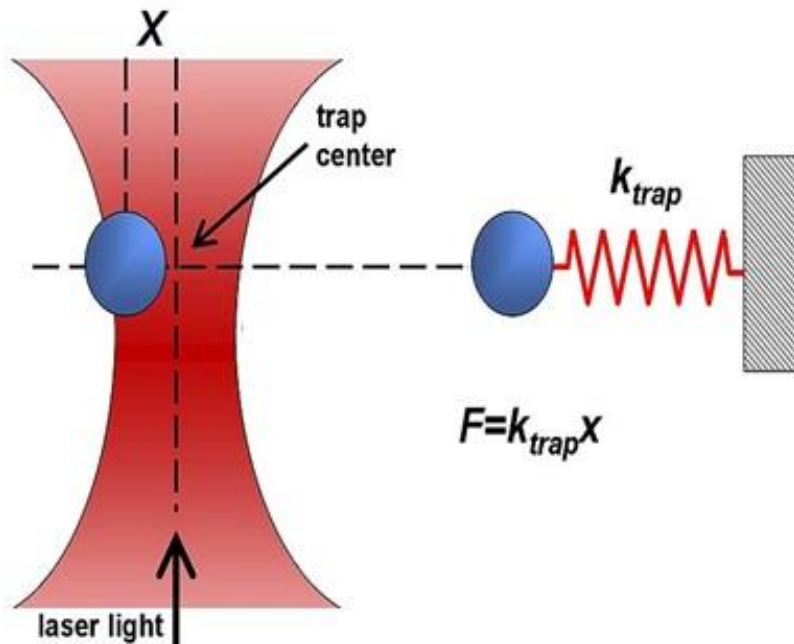

- Objects are attracted to the center of the beam
- The force applied on the object depends linearly on its displacement from the trap center just as with a simple spring system
- The spring constant, or stiffness : optical gradient, laser power, properties of the trapped object and solvent

# Calibration in the flow cell

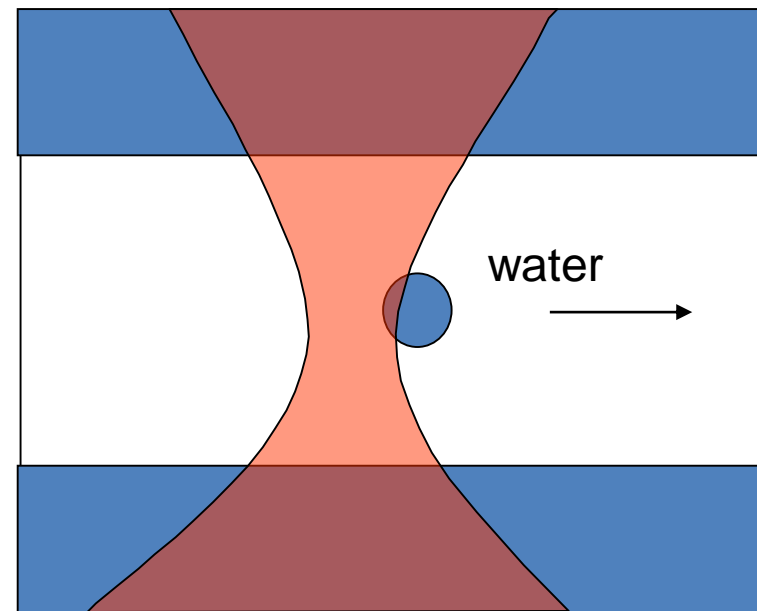
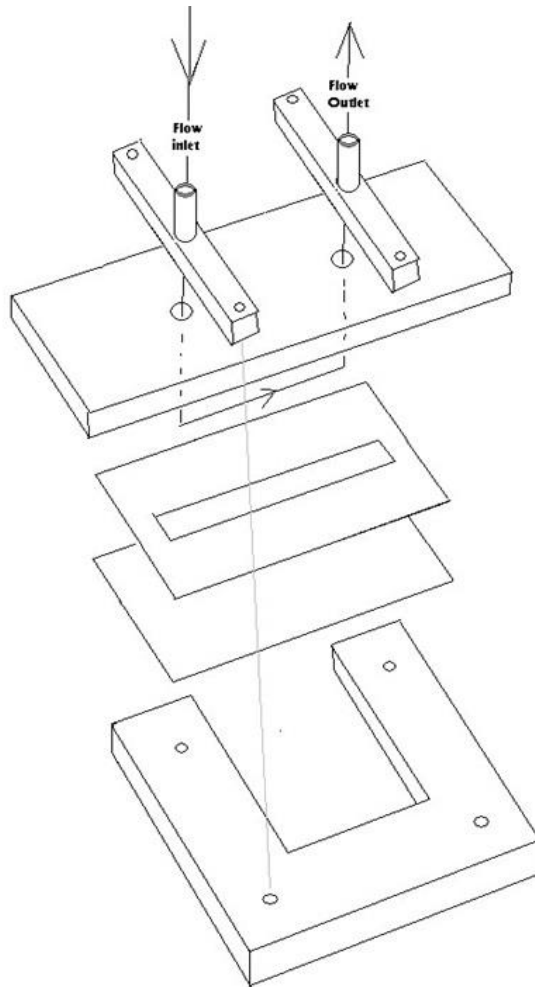

# Calibration in the flow cell

*We apply a force to the trapped sphere by flowing water through the cell. This force is dependent on radius  $r$ , viscosity  $\eta$ , and velocity  $v$  of the water*

$$F_{drag} = 6\pi\eta rv$$

*Within the limits of the strength of the trap, the sphere remains trapped, but undergoes a displacement under the influence of this external force just like a mass on a spring*

$$F = kx$$

# Apply a known force

If a known force is applied, and the displacement is measured, the 'stiffness' of the optical trap may be determined

$$k = \frac{6\pi\eta r v}{x}$$

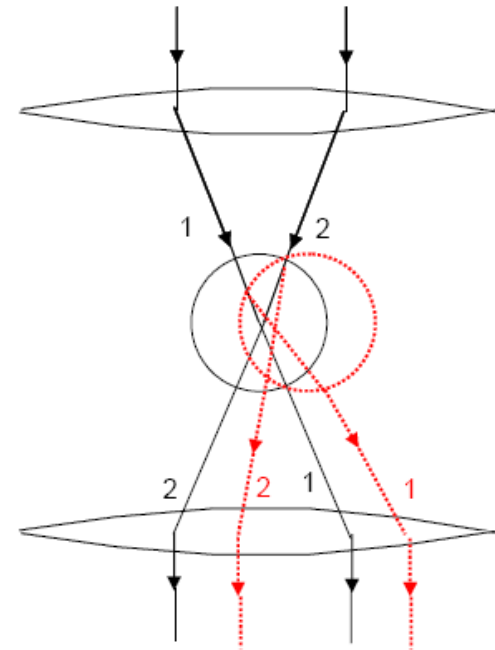

# Applications

- Motor proteins such as kinesins and myosins: The step size, stall-force force and processivity
- Measurement of RNA polymerase advancing a single base pair (0.34 nm) along DNA the mechanical
- Distruption of cchemical bonds (nanonewton forces)
- Assay of nucleic acid folding kinetics ( $\sim 0.1$  pN)
- Manipulation of single cells ( $\sim 100$   $\mu\text{m}$ ) to probe the strength and location of receptor binding and adhesion or to measure traction and adhesion forces
- Viscoelastic properties: force-extension relationship of individual polymers, in particular of nucleic acids
- Analysis of ligand and antibody binding
- Multistate unfolding of single proteins and nucleic acid structures

# Applications

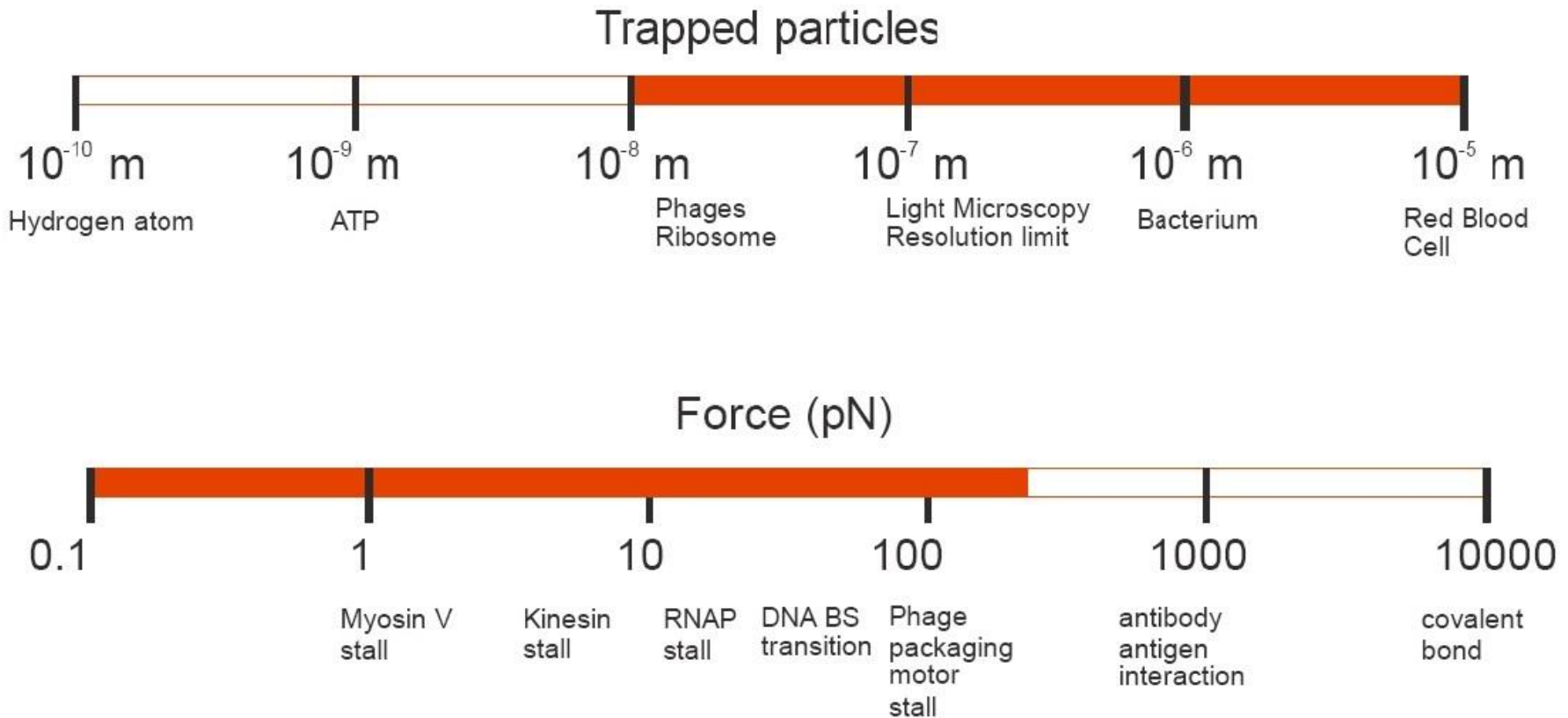

# Molecular Motors

Molecules that convert the chemical energy into mechanical work

Functions: cell motility, cellular transport, cell division and growth,...

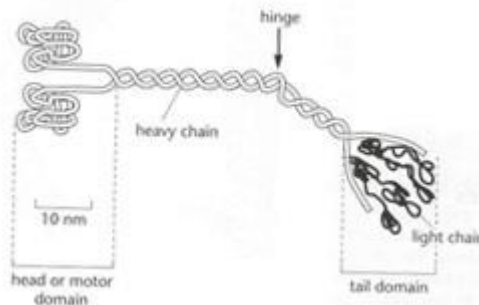

*Kinesin*

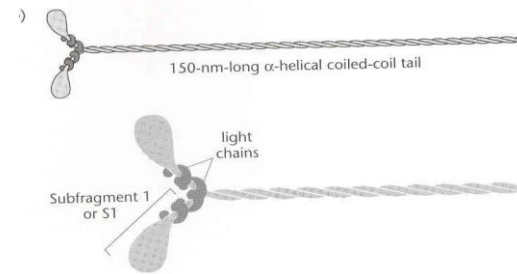

*Myosin-II*

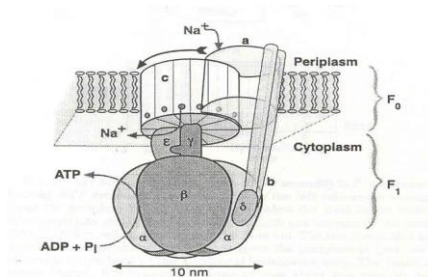

*$F_0F_1$ -ATPase*

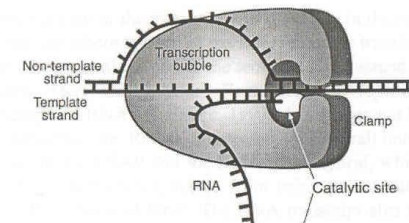

*RNA-polymerase*

# Motor Proteins

Velocity: 0.01-100 nm/s

Step Sizes: 0.3-40 nm

Forces: 1-60 pN

Fuel: hydrolysis of ATP

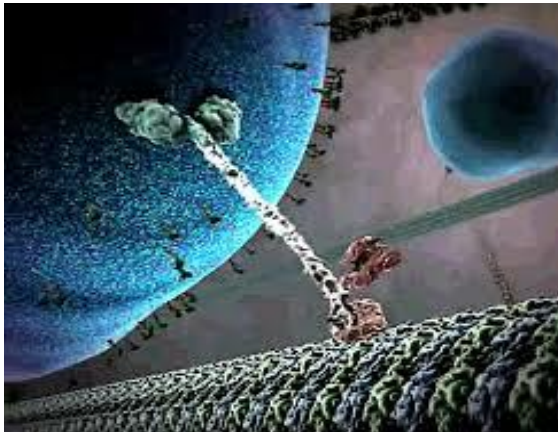
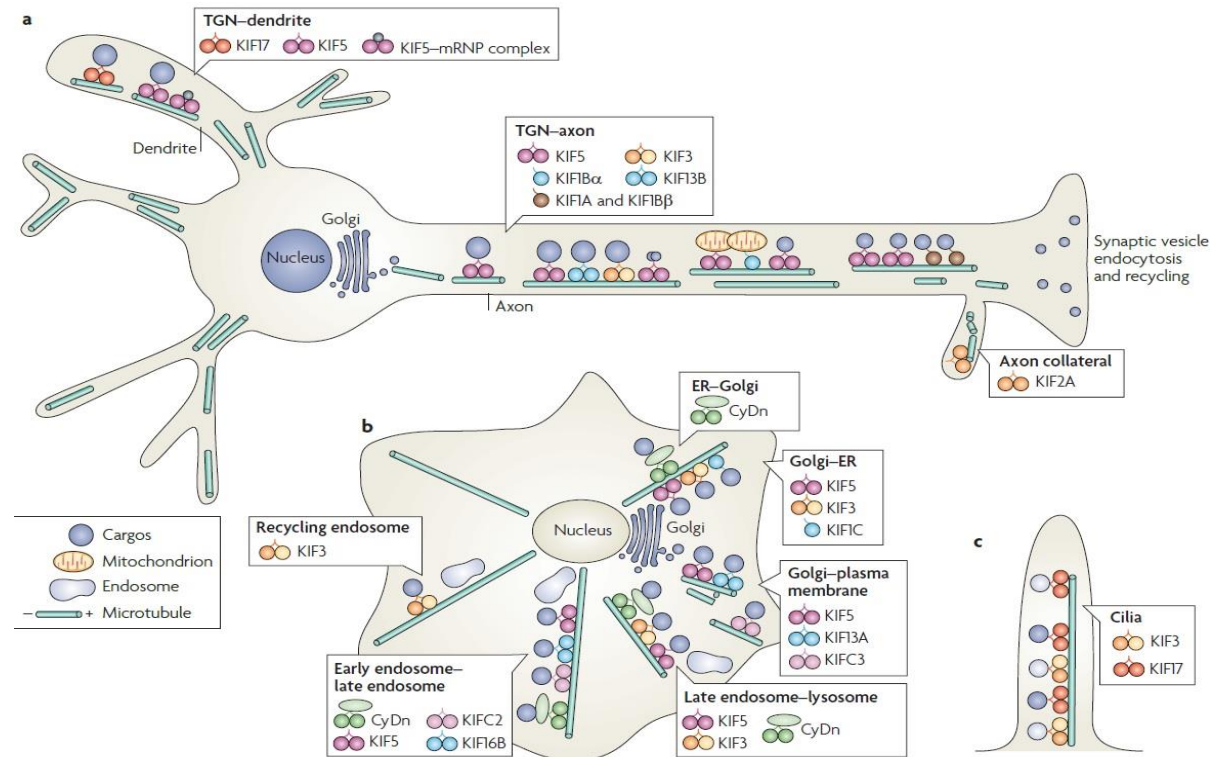



# Kinesin

*Motor proteins in eukaryotic cells*

*Heterotetrameric fast axonal organelle transport motor consisting of 2 identical motor subunits*

*Move along microtubule filaments, and are powered by the hydrolysis of ATP*

*Movement of kinesins in cellular functions: Mitosis, meiosis and transport of cellular cargo, such as in axonal transport.*

*Walk towards the plus end of a microtubule, which, in most cells, entails transporting cargo from the centre of the cell towards the periphery*

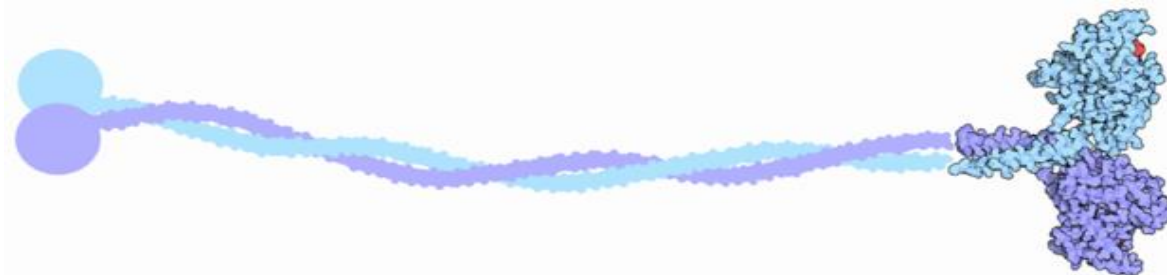

# Kinesin

*Kinesin has two ends. One end is the “tail end” which attaches to whatever is being transported vesicle or organelle. The other end has two “heads” which attaches to a microtubule. These two heads walk along the microtubule*

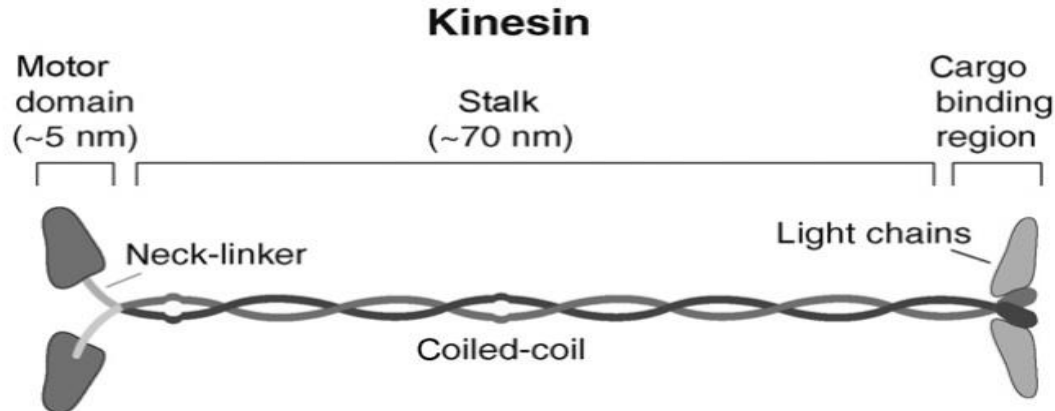

*Kinesin is composed of two identical heavy chains and two light chains. The heavy chain contains an N-terminal globular ATP-binding motor domain that possesses catalytic and binding activity, a neck-linker element that connects the motor domain to the coiled-coil domain, and a C-terminal light chain and cargo-binding region. The coiled coil is interrupted by a few hinge regions that give flexibility.*

# Microtubule

*Component of the cytoskeleton*

*Cylindrical polymers of tubulin: can grow as long as 25 micrometers*

*Outer diameter of microtubule: 25 nm.*

*Functions: cell structure and providing platforms for intracellular transport*

*Alternating pattern of  $\alpha$ - and  $\beta$ -tubulin*

*Alternation plays important role in Kinesin movement*

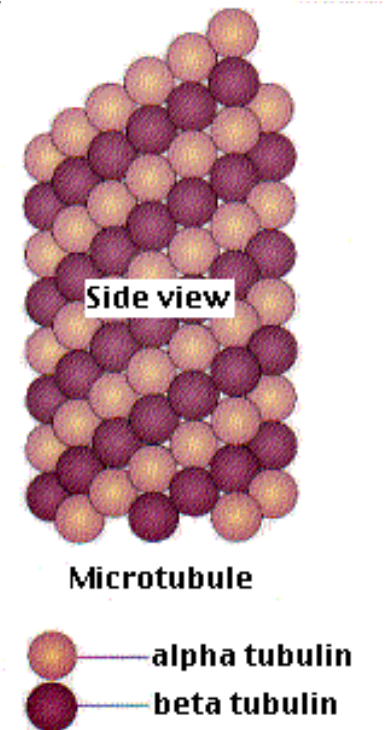
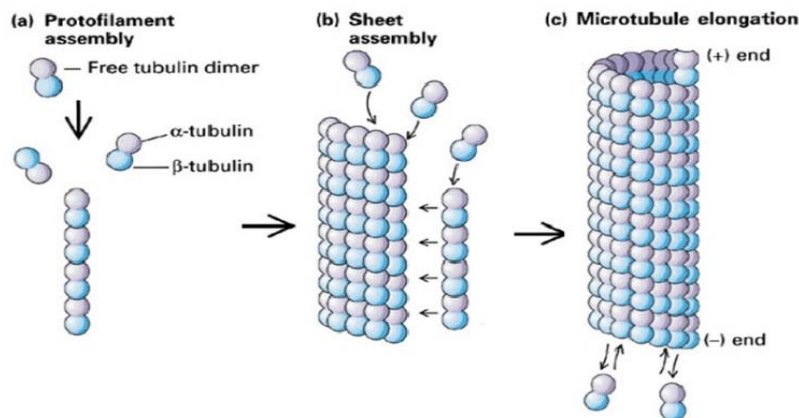

# Hand-over-hand walking

Cargo proteins bound by kinesins are vesicle or organelle.

Organelle membranes contain transmembrane receptor proteins that bind kinesins. Kinectin is an ER membrane receptor for kinesin-I.

Scaffolding proteins, first identified as being involved in assembling signal protein complexes, mediate binding of kinesin light chains to some cargo proteins or receptors

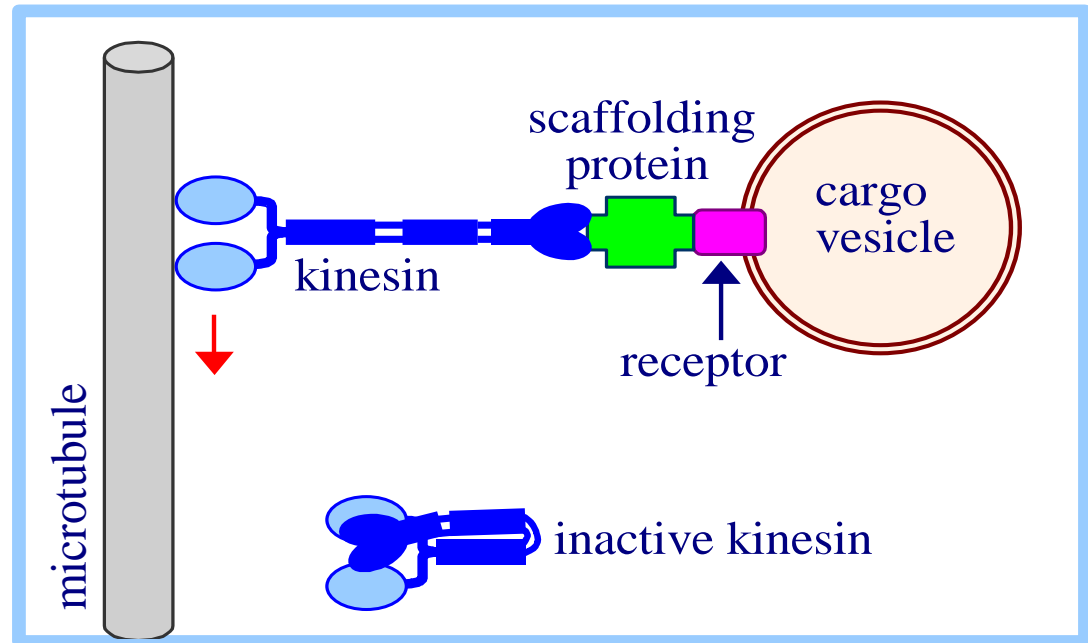

In absence of cargo, the kinesin heavy chain stalk folds at hinge regions, bringing heavy chain tail domains into contact with the motor domains. In this folded over state kinesin exhibits decreased ATPase activity and diminished binding to microtubules. This may prevent wasteful hydrolysis of ATP by kinesin when it is not transporting cargo

# Hand-over-hand walking

Consensus stepping sequence of kinesin. A nucleotide-driven conformational change in the tightly microtubule-interacting front head displaces the weakly microtubule-interacting rear head toward the microtubule plus-end, biasing its diffusional search and rebinding to the next available microtubule-binding site in front of its partner head. Kinesin's center of mass advances 8 nm

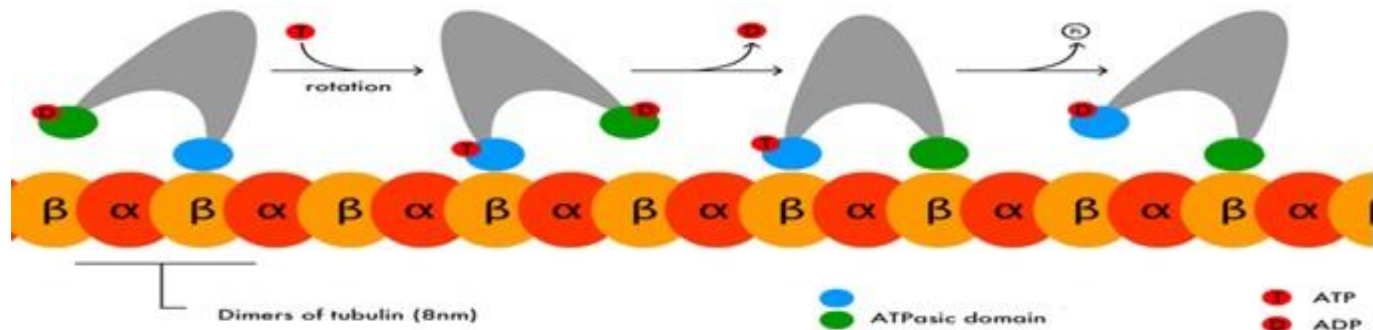
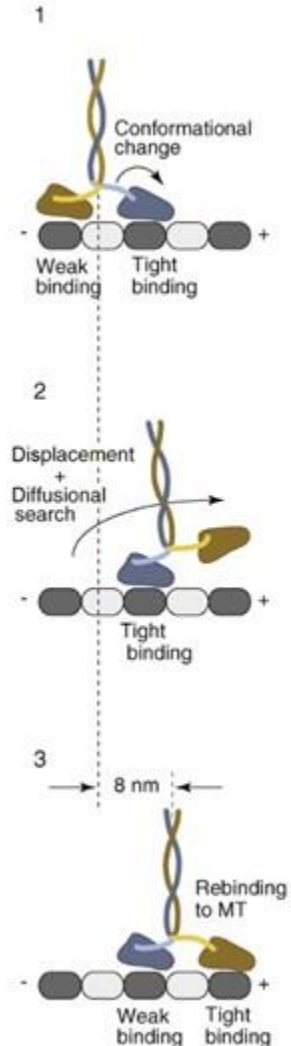

# Single-molecule analysis of kinesin motility

In order to track kinesin motion, we attach the molecules to microscopic beads. Kinesin itself is much too small to see in the optical microscope, so the beads serve as markers that can be tracked with very high precision. The beads also act as "handles", through which we can apply force using an optical trap. Applying tension reduces Brownian motion of the bead, making it clear that kinesin moves in a stepwise fashion, in 8 nm increments. For each 8nm step, kinesin uses a single fuel molecule, hydrolysing one ATP molecule into ADP and inorganic phosphate

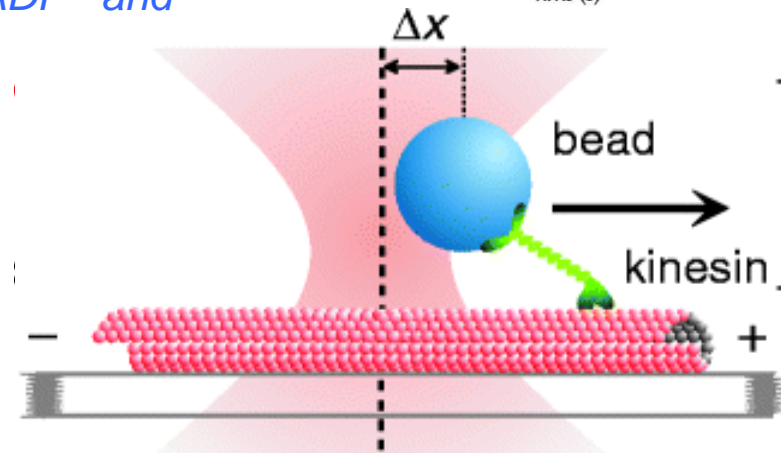
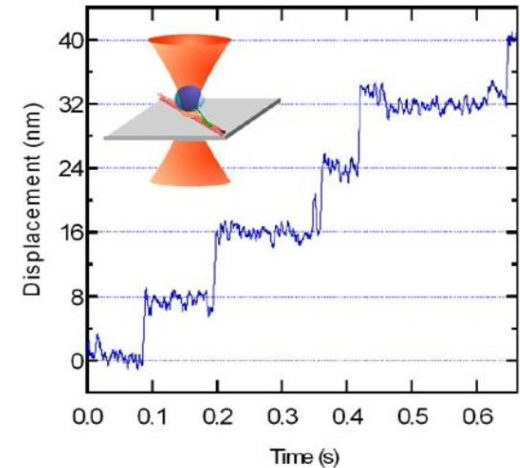

Schnitzer and Block, *Nature*, 388, 386-390 (1997)

Hua et al., *Nature*, 388, 390-394 (1997)

Coy et al., *J. Biol. Chem.*, 274, 3667-3671 (1999)

Nishiyama et al., *Nature Cell Biology*, 4, 790-797 (2002)

# Lab on a chip

- Low volumes
- Fast analysis
- High level process control
- Safe
- Low fabrication costs



Microfluidic growth chambers with optical tweezers for full spatial single-cell control and analysis of evolving microbes

Christopher Probst, Alexander Grünberger, Wolfgang Wiechert, Dietrich Kohlheyer \*

Institute of Bio- and Geosciences, IBG-1: Biotechnology, Forschungszentrum Jülich GmbH (Research Centre Jülich), Jülich, D-52428, Germany

- Individual cell manipulations by combining laser tweezers with microfluidic cell cultivation
- Growth of irradiated bacteria
- Investigations in laminar flow or diffusive environments in order to unravel single cell behavior

# Lab on a chip

*Microfluidic microbial cultivation device fabricated by PDMS using a lithography fabricated multilayer master for single cell and microcolony growth analysis.*

*Microfluidic device of 20 mm × 30 mm × 3 mm*

*200 parallel “growth chambers” (30 μm × 40 μm × 1.2 μm)*

*100 “growth pockets” with a single entrance (30 μm × 40 μm × 1.2 μm) allowing single-cell inoculation exclusively by OT*

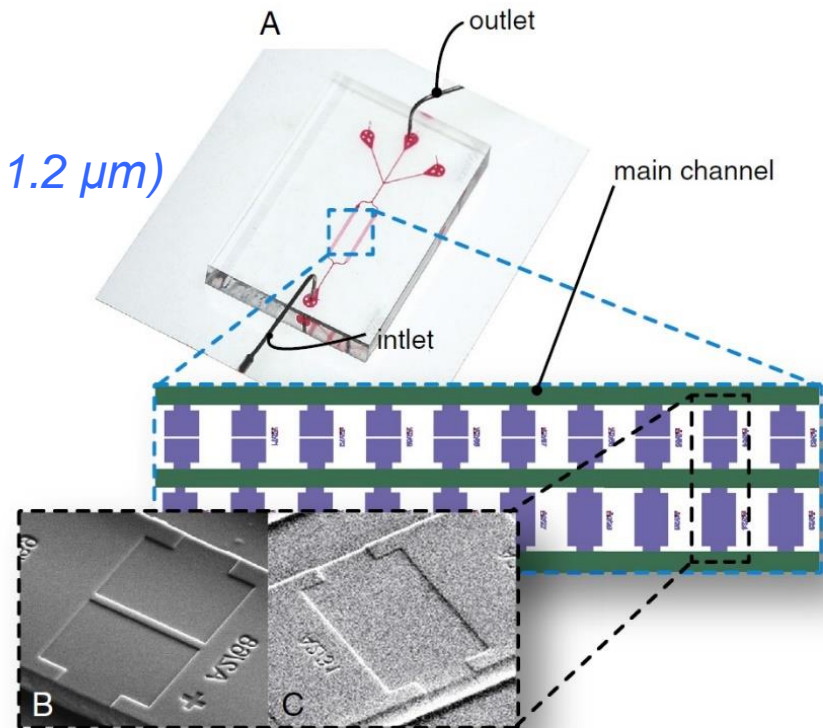



# Lab on a chip

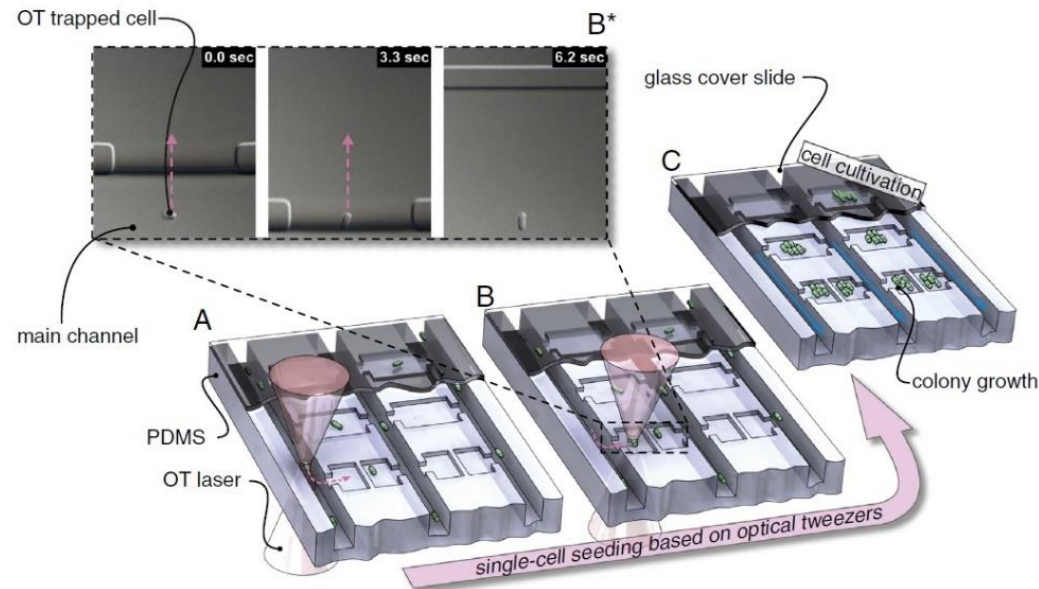

## EXPERIMENTAL CONDITIONS

- Seeding Flow: 400 – 700 nl/min ( $Re = 0.04$ )
- OT seeding: cell exposure time of 1 min at 60 mW
- Temperature: 37 °C
- Bacteria: *Escherichia coli*

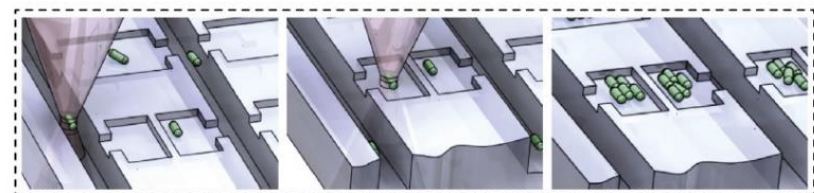

Time-lapse images: every 5 min for 8 h



---> optical tweezers movement   
  cultivation chamber (flow-based seeding)   
  cultivation pockets (OT-based seeding only)

# OT – Hydrodynamically seeding

OT manipulation of single bacteria cells doesn't affect cell growth

A minimal laser dosage can be used to manipulate and seed single cells to gain more control over an evolving microcolony

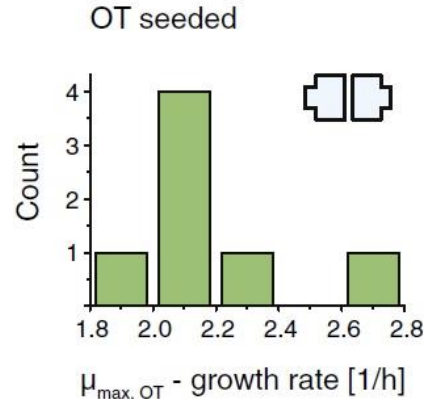
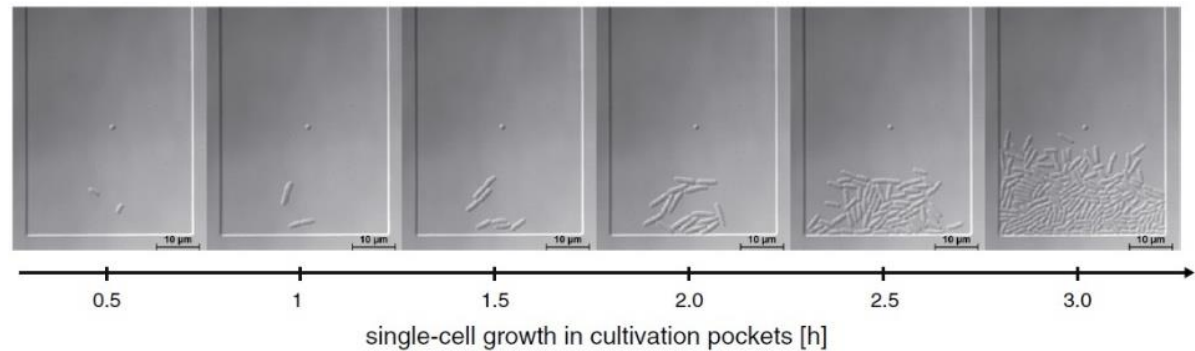

$$\bar{\mu}_{\max, OT} = 2.16 \pm 0.09 [1/h]$$

$$\bar{t}_{d, OT} = 19.28 \pm 0.82 [min]$$

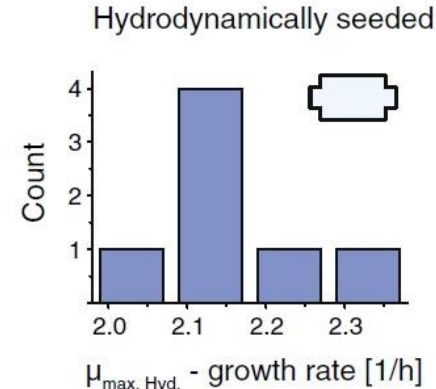

$$\bar{\mu}_{\max, Hyd.} = 2.18 \pm 0.25 [1/h]$$

$$\bar{t}_{d, Hyd.} = 19.22 \pm 1.96 [min]$$

# OT – Hydrodynamically seeding

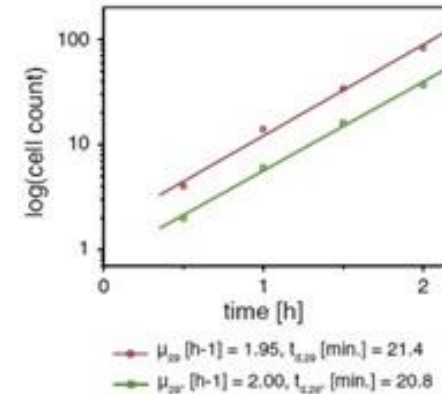
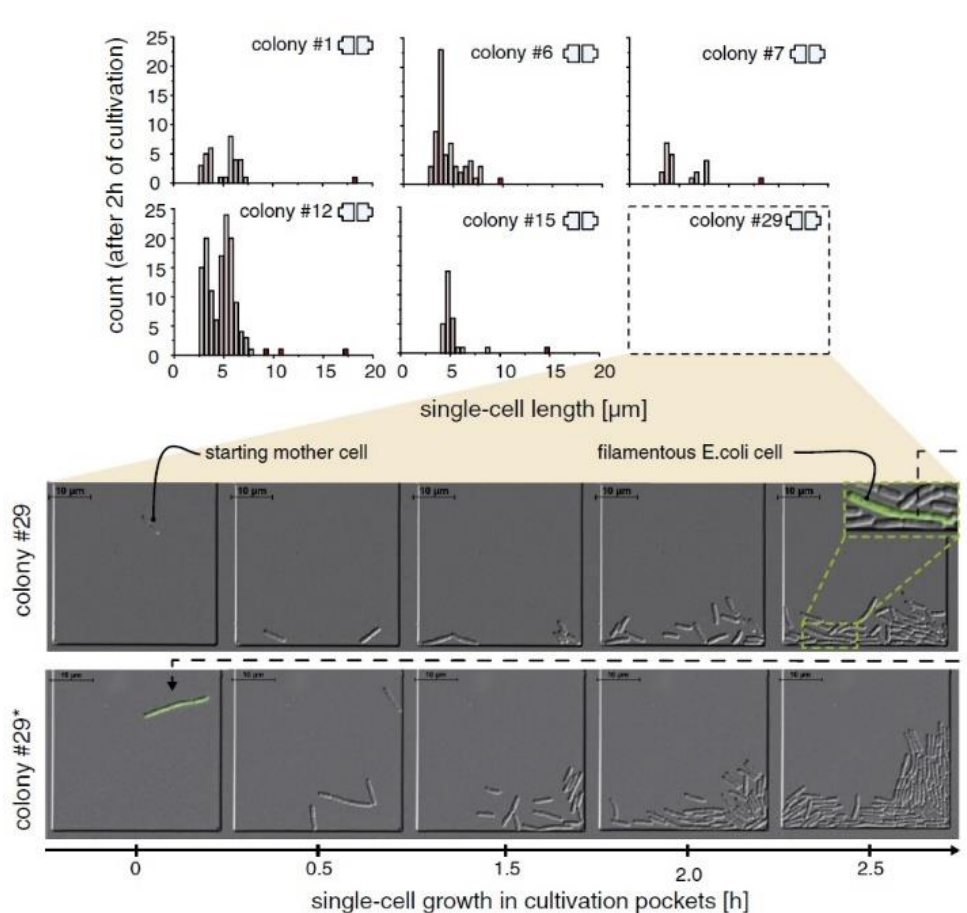

*Successfully application of OT and isolation of a filamentous E. coli*

*Filamentation is unlikely to be caused by external stress factors such as nutrient depletion*

**THIS METHOD HAS GREAT POTENTIAL FOR SELECTING SPECIFIC CELLS**

# Concluding Remarks

*We can isolate a single molecule and simplify the system that we are studying significantly in the absence of interactions between these molecules that might complicate the analysis*

*We can measure the properties of a single molecule, particles and cells using a non-invasively and non-destructively technique*