

ADAPTIVE IMPACT ABSORPTION AND APPLICATIONS TO LANDING DEVICES

J. Holnicki-Szulc, P.Pawłowski, M.Mikułowski, C.Graczykowski

Institute of Fundamental Technological Research, SMART- TECH Centre
Polish Academy of Sciences

Świętokrzyska 21, 00-049 Warsaw, Poland

e-mail: holnicki@ippt.gov.pl, web: <http://smart.ippt.gov.pl>

Keywords: Adaptive Impact Absorption, Controlled Shock-absorbers, Adaptive Landing Gear, Inflatable Structures

This paper demonstrates progress in Adaptive Impact Absorption (AIA) research field obtained recently in our research group and is based on previously published conference communicates. The monograph (Ref.[1]), under preparation, will present soon more detailed discussion of the considered problems. In contrast to the standard passive systems the proposed AIA approach focuses on active adaptation of energy absorbing structures (equipped with sensor system detecting and identifying impact in real time and controllable semi-active dissipaters, so called structural fuses) with high ability of adaptation to extreme overloading. A semi-active or fully-active solutions can be applied, which depend on constant or time-dependent modifications realized via controllable dissipative devices. Feasible, adaptive dissipative devices under considerations can be based on MR fluids or (hydraulic or pneumatic) piezo-valves. The presentation will be devoted to the following applications of AIA concept: Adaptive Landing Gears (ALG) for mitigation of exploitative aircraft loads and adaptive flow control based airbags for emergency landing of the helicopter.

The undertaken research is oriented towards the requirements of high impact energy absorption e.g. in the structures exposed to risk of extreme blast, thin wall tanks with high impact protection, vehicles with high crashworthiness, protective barriers, etc. Typically, suggested solutions focus on the design of passive energy absorbing systems frequently based on the aluminium or steel honeycomb packages characterised by a high ratio of specific energy absorption. However high is the energy absorption capacity of such elements they still remain highly redundant structural members, which do not carry any load in an actual operation of a given structure. In addition, passive energy absorbers are designed to work effectively in pre-defined impact scenarios only.

Adaptive Impact Absorption (AIA) focuses on *active adaptation* of energy absorbing structures to actual dynamic loading by using system of sensors detecting and identifying impact in advance and by applying controllable dissipaters (structural fuses) to change structure characteristics in real time, cf Ref. [1]. The term *active adaptation* refers to the particular case of actively controlled energy dissipater, where the need for external sources of energy is minimized and the task for actuators is reduced to modify local mechanical properties rather than to apply externally generated forces. The purpose of the AIA approach is to smooth down the impact coming from standard service loads (e.g. for reduction of fatigue) or to sustain critical impact overloading with minimal damage of protected structure. Semi-active or fully-active solutions with constant or time-dependent modifications can be realised via controllable dissipative devices with no need for important power supply based on magneto-rheological fluids, shape memory alloys or piezo-materials. The exemplary adaptive structure for impact absorption is composed of elements with controllable yield pressures which allow to obtain various folding sequences (Fig. 1).

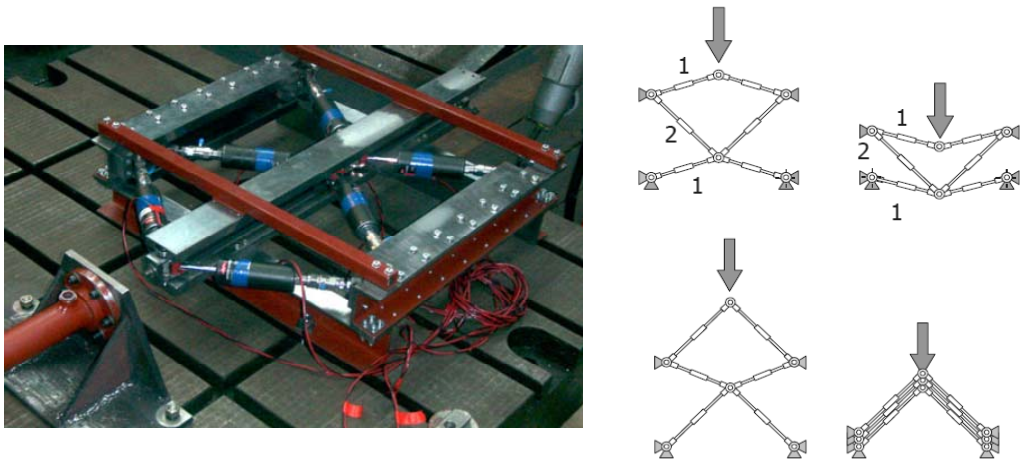

Fig 1. Adaptive Impact Absorption in Multi-Folding Microstructure: a) experimental setup
b) various folding modes of the absorber

The first part of the paper deals with the problem of the design of adaptive shock absorbers to be applied in aircraft landing gears. Typically, aircraft shock absorbers are designed as passive devices with characteristics satisfying the hardest expected landing impact conditions. However, in majority of cases the variation of real working conditions is below these critical levels and the passive shock absorber is too stiff to perform optimally the landing scenario.

In contrast to the passive systems, the proposed adaptive landing gear utilizes the system of sensors which recognizes the actual landing conditions and activates energy absorbing components realizing a pre-design strategy of optimal impact energy dissipation. Such active landing gear was successfully designed and manufactured during recently finished ADLAND project, cf Ref. [2]. The objectives of the project were:

- to develop a concept of adaptive shock-absorbers
- to develop new numerical tools for design of adaptive vehicles and for simulation of the adaptive structural response to an impact scenario
- to develop technology for actively controlled shock-absorbers applicable in landing gears (two considered options: MR fluid-based and piezo-valve-based)
- to design, model and perform repetitive impact tests of the adaptive landing gear model with high impact energy dissipation effect.
- to design, produce and test in flight the chosen full-scale model of the adaptive landing gear.

Two classes of semi-active device were developed and evaluated: one based upon smart fluids, the other on adaptive valves. A Smart fluid is defined as one in which the resistance to flow can be controlled through the application of an external field. Magnetorheological fluids form a special class of smart fluids which show particularly strong changes in behaviour under an applied magnetic field. The effective viscosity of the fluid can be reversibly increased by orders of magnitude within milliseconds. When the magnetorheological fluid is employed as the working medium in a suitable energy-dissipating device (Fig. 2a) then the form of the developed force (and the associated energy dissipation) can be varied continuously as a function of a low-power control signal.

Alternative approach to design of adaptive shock-absorbers was based on adaptive valves based utilizing piezo-actuators (Fig. 2b). The damping characteristics of the landing gear was controlled by modifying a conventional hydraulic circuit by actuating valves and changing an hydraulic restrictor size.

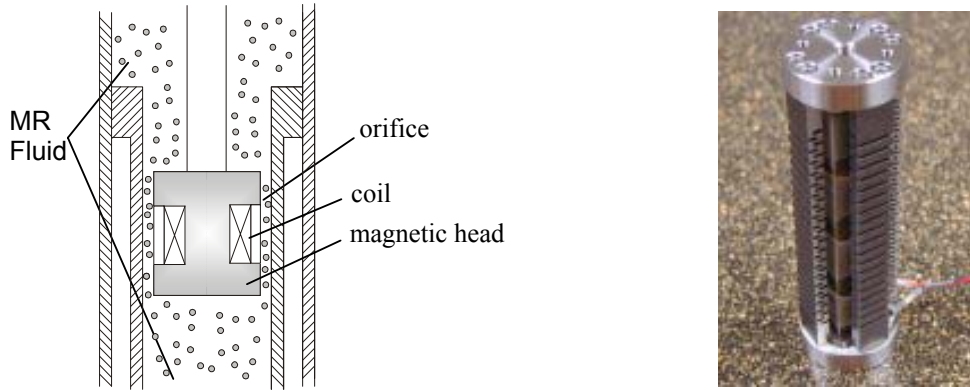

Fig.2 a) magneto-rheological damper; b) piezoelectric actuator made by CEDRAT

The system of control designed for the adaptive shock absorber was integrated with ultrasonic system of sink speed and height measurement. Estimation of the sink velocity and height was based on measurement of propagation time of an ultrasonic impulse. The controller provided a control signal for the amplifier of the actuator through digital to analogue converter. The optimal control sequences were stored in memory of the controller and could be constant, time-dependent or dependent on an auxiliary reference signal (e.g. oil pressure in the shock absorber).

Full-scale drop tests performed at the Institute of Aviation, (Warsaw, Poland) on landing gear M28 SKYTRUCK equipped with piezo-valve based shock absorber (Fig.3a) illustrate the corresponding reduction in load peaks obtained for different landing scenarios (Fig. 4). Conducted field tests (Fig.3b) had confirmed the correct functioning of the designed measurement and control systems, as well as the effectiveness of the whole adaptive landing gear.



Fig.3 a) Test Bench in Institute of Aviation, Warsaw, Poland; b) field testing of Adaptive Landing Gear in PZL Mielec

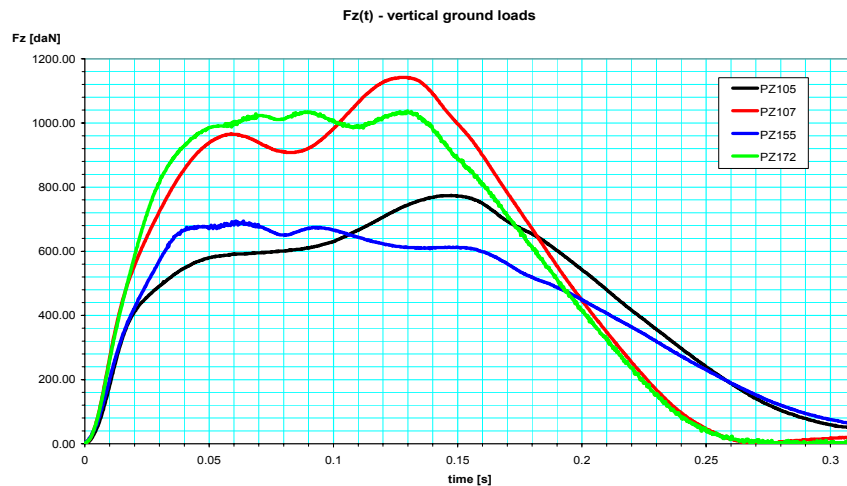

Fig. 4 Experimental results obtained in ADLAND project by Institute of Aviation: Pz105 – low kinetic energy of landing, no control ; Pz155 – low kinetic energy of landing, **optimal control**; Pz107 – high kinetic energy of landing, no control; Pz172 - high kinetic energy of landing, **optimal control**.

The second aeronautical application under development is an adaptive external airbag for helicopter. The system is designed for extremely severe, emergency landing. It consists of a multi-chamber air filled cushions attached to the helicopter undercarriage (cf. Fig. 5). Deployment of these cushions is executed just before touchdown by means of pyrotechnic system. Release of pressure is due to fabric leakage and additional piezoelectric based controllable high speed and stroke valves.

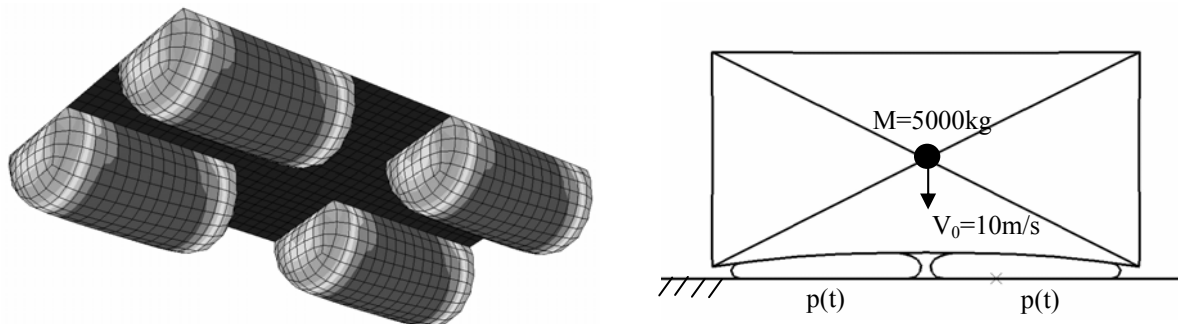

Fig 5a. Considered model of the airbags; 5b. Simplified simulation of landing

In numerical example the considered helicopter is modelled by deformable beams and point masses. The total mass of the model equals 5000kg (mass of a typical civil helicopter). The velocity of emergency landing equals 10m/s which is equivalent to free falling from 5,1m. Estimated dimensions of the airbag are $4\text{m}^2 \times 0.5\text{m}$. Constant pressure in the airbags necessary to avoid direct collision with ground calculated directly from energy balance equals 1.25 atm overpressure (2.25 atm total pressure).

Control strategy is oriented towards: minimization of accelerations acting on passengers, alleviation of forces acting on the helicopter and stresses arising in undercarriage and stabilization of helicopter during touchdown. To fulfil objectives mentioned, the whole stroke of the airbag is used during the landing, the total force acting on helicopter is kept on constant level and significant release of pressure is applied when helicopter velocity drops to zero. The subsequent peaks on pressure plot (Fig. 6a) are related to the rebounds of the falling object. In applied control strategy the amount of the gas inside the airbag has to increase strongly at the beginning of the process (inflation of the airbag) and then the gas is gradually removed.

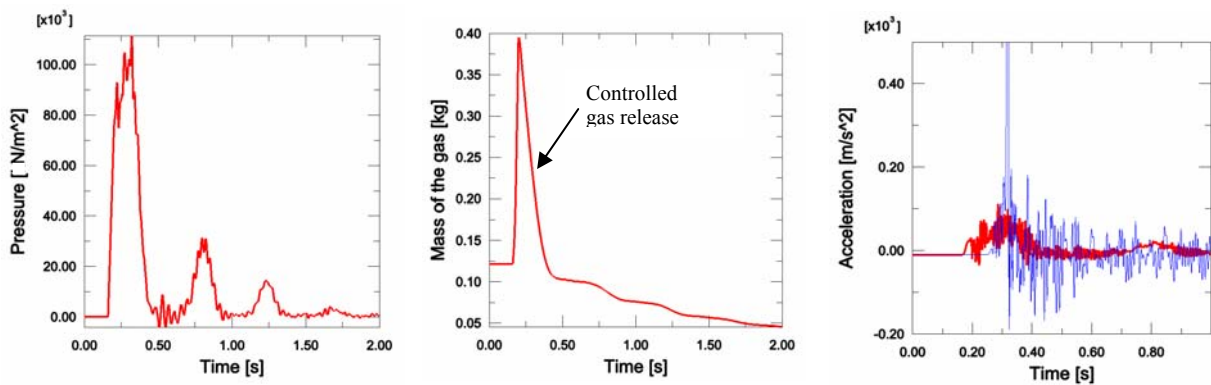

Figure 6. Applied control strategy: a) change of pressure inside the airbag, b) mass of the gas inside airbag; c) reduction of accelerations obtained as a result of applied control strategy

Conducted simulations prove that proposed devices and control strategies efficiently decrease arising accelerations and hence increase the safety of emergency landing.

REFERENCES:

- [1] Holnicki-Szulc, J. (Ed.), *Smart Technologies for Safety Engineering*, J.Wiley, 2008
- [2] EU Project ADLAND IST-FP6-2002-2006, <http://smart.ippt.gov.pl/adland/>.