

Classification of thin shell models deduced from the nonlinear three-dimensional elasticity. Part II : the strongly curved shells

A. HAMDOUNI,⁽¹⁾ O. MILLET⁽²⁾

⁽¹⁾LEPTAB, University of La Rochelle,
Av. Crepeau, 17042 La Rochelle cedex 01, France.
e-mail:aziz.hamdouni@univ-lr.fr

⁽²⁾LML, CNRS, Université de Lille 1, Bd. Paul Langevin,
59655 Villeneuve d'Ascq, France.
e-mail:olivier.millet@univ-lille1.fr

IN THE FIRST part of this paper we have deduced a classification of asymptotic shallow shell models with respect to the level of applied forces, from the non-linear three-dimensional elasticity. We have used a constructive approach based on a dimensional analysis of the non-linear three-dimensional equilibrium equations, which naturally makes appear dimensionless numbers characterizing the applied forces (\mathcal{F} and \mathcal{G}) and the geometry of the shell (ε and \mathcal{C}). To limit our study to one-scale problems, these dimensionless numbers are expressed in terms of the relative thickness ε of the shell, considered as the perturbation parameter. In the first part, we have studied the case of shallow shells corresponding to $\mathcal{C} = \varepsilon^2$. In the second part of this paper, we will study the case of strongly curved shells for which $\mathcal{C} = \varepsilon$. The classification that we obtain is then more complex. It depends not only on the force levels, but also on the existence of inextensional displacements which keep invariant the metric of the middle surface of the shell.

Key words: Nonlinear elasticity, Shell theory, Dimensional analysis, Asymptotic methods

1. Introduction

THIS PAPER is a continuation of [10] to which we will refer for the definitions and notations not explained here.

We recall that in the first part of this paper we have developed a constructive approach which enables us to deduce a classification of asymptotic shell models from the three-dimensional nonlinear elasticity. This approach is based on a dimensional analysis of nonlinear equilibrium equations which naturally makes appear dimensionless numbers, ε and \mathcal{C} which reflect the geometry of the shell, \mathcal{F} and \mathcal{G} which characterize the applied forces. The reduction to a one-scale problem leads us to link \mathcal{C} , \mathcal{F} and \mathcal{G} to the small reference parameter ε . In the first part, we have established a classification of shallow shells models (corresponding to

$\mathcal{C} = \varepsilon^2$) with respect to the level forces, from asymptotic expansion of the three-dimensional equations of nonlinear elasticity. In the second part of this paper, we propose to apply the same approach for strongly curved shells for which $\mathcal{C} = \varepsilon$. The classification obtained also depends on the geometric rigidity of the middle surface of the shell. However, contrary to the first part of this paper, the shell is now assumed to be clamped only on a part of the lateral surface and free on the other part.

The geometric rigidity of the shell is characterized by the existence of inextensional displacements which keep invariant the metric of the middle surface, in the linear and the nonlinear case. As the shell is assumed to be clamped only on a part of its lateral surface, such inextensional displacements are possible. Thus, in what follows, we will use the following terminology :

– a non-inhibited or inhibited shell in the nonlinear range (or just non-inhibited/inhibited shell) will characterize a shell whose middle surface admits or not nonlinear inextensional mappings or displacements¹⁾ (see (5.2) for the mathematical definition).

– a non-inhibited or inhibited shell in the linear range (or linearly non-inhibited/inhibited shell) will characterize a shell whose middle surface admits or not linear inextensional displacements²⁾ (see (5.64) for the mathematical definition).

Let us notice that the definition of a non-inhibited shell in the nonlinear range used here is different from the one of “bendable surface” according to the terminology of SZWABOWICZ [24]. It is to be reminded that the importance of such inextensional deformations in shell theory is known since a long time (see for example LOVE [12], NOVOZHILOV [17], GOLDENVEIZER [9]). However, whereas the study of inextensional displacements in linear theory has been systematized in [2][8][19][20][26], only a few works on nonlinear inextensional displacements exist [24].

Moreover, to our knowledge there is no work which studies the link between linear and nonlinear inextensional displacements. In many practical cases, if the shell is inhibited (respectively non-inhibited) in the nonlinear range, then it is linearly inhibited (respectively non-inhibited). However, some examples exist which refute this observation. Indeed, let us consider half a sphere clamped on its lateral surface. If it is deformed so as to obtain the symmetric configuration with respect to the base, the transformation is inextensional in the nonlinear range, whereas it is well known that half a sphere completely clamped on its lateral surface is linearly inhibited (see [2]).

¹⁾The nonlinear inextensional mappings keep invariant the *nonlinear metric* of the middle surface.

²⁾The linear inextensional displacements keep invariant the *linearized metric* of the middle surface.

2. Decomposition of the three-dimensional problem

As in the first part, we consider a shell of $2h_0$ thickness, whose middle surface is ω_0^* , which occupies the domain $\bar{\Omega}_0^*$ in its reference configuration, where $\Omega_0^* = \omega_0^* \times]-h_0, h_0[$ is an open set of \mathbb{R}^3 . We recall that ω_0^* denotes a connected surface embedded in \mathbb{R}^3 , whose diameter is L_0 , with a "smooth enough" boundary γ_0^* . We note N_0 the unit normal to ω_0^* , C_0^* its curvature operator, q_0^* a generic point of $\bar{\Omega}_0^*$ and $\Gamma_0^{*\pm} = \bar{\omega}_0^* \times \{\pm h_0\}$ the upper and lower faces of the shell. Contrary to the first part of this paper, the shell is now assumed to be clamped only on a portion $\Gamma_0^{1*} = \gamma_0^{1*} \times [-h_0, h_0]$ of the lateral surface $\Gamma_0^* = \gamma_0^* \times [-h_0, h_0]$, and free on the other portion $\Gamma_0^{2*} = \gamma_0^{2*} \times [-h_0, h_0]$, where $(\gamma_0^{1*}, \gamma_0^{2*})$ denotes a partition of γ_0^* . Thus inextensional displacements are possible.

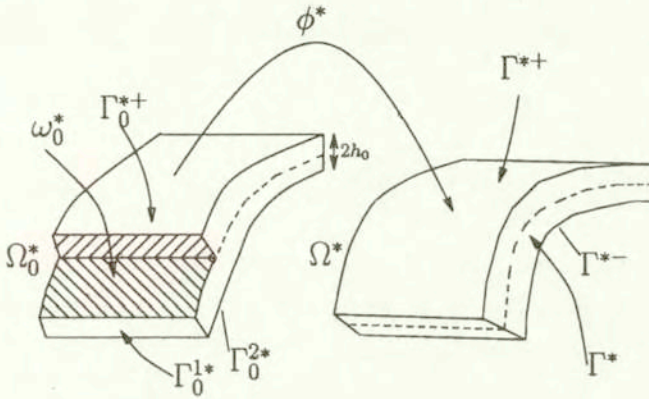

FIG. 1. Initial and final shell configuration.

Within the framework of nonlinear elasticity, the unknown mapping $\phi^* : \bar{\Omega}_0^* \rightarrow \mathbb{R}^3$ and the second Piola-Kirchhoff tensor Σ^* solve the equilibrium equations :

$$\begin{aligned}
 \text{Div}^*(\mathcal{H}^*) &= -\bar{f}^* && \text{in } \Omega_0^*, \\
 \bar{\mathcal{H}}^* N_0 &= \pm g^{*\pm} && \text{on } \Gamma_0^{*\pm}, \\
 \phi^* &= i_d && \text{on } \Gamma_0^{1*}, \\
 \bar{\mathcal{H}}^* n_0 &= 0 && \text{on } \Gamma_0^{2*},
 \end{aligned}
 \tag{2.1}$$

with $\mathcal{H}^* = \Sigma^* \bar{F}^*$, where $F^* = \frac{\partial \phi^*(q_0^*)}{\partial q_0^*} = I_3 + \frac{\partial U^*}{\partial q_0^*}$ denotes the linear tangent mapping to ϕ^* , n_0 the unit external normal to Γ_0^* , $f^* : \bar{\Omega}_0^* \rightarrow \mathbb{R}^3$ and $g^{*\pm} : \Gamma_0^{*\pm} \rightarrow \mathbb{R}^3$ the applied body and surface forces, and i_d the identity mapping of \mathbb{R}^3 . Let us recall that in the framework of Saint-Venant Kirchhoff materials,

Σ^* is linked to the nonlinear Green-Lagrange strain tensor $E^* = (\overline{F^*} F^* - I_3)/2$ by the constitutive relation $\Sigma^* = \lambda \text{Tr}(E^*)I_3 + 2\mu E^*$, where I_3 denotes the identity of \mathbb{R}^3 , λ and μ the Lamé constants of the material.

To make the expansion of the boundary condition $\overline{\mathcal{H}^*} n_0 = 0$ on Γ_0^{2*} , we must have an explicit expression of the normal n_0 with respect to the unit normal ν_0 to γ_0^* . We have the following proposition which has been proved in [6] :

PROPOSITION 1. Let ω_0^* be a connected surface embedded in \mathbb{R}^3 . Let us consider the shell of $2h_0$ thickness which occupies the domain

$$\overline{\Omega_0^*} = \{q_0^* = p_0^* + z^* N_0 \quad \text{where } p_0^* \in \overline{\omega_0^*} \text{ and } z^* \in [-h_0, +h_0]\}.$$

Then the unit external normal n_0 to the lateral surface Γ_0^* is given by:

$$(2.2) \quad n_0 = \frac{1}{\|\kappa_0^{*-1} \nu_0\|} \kappa_0^{*-1} \nu_0$$

with $\kappa_0^* = I_0^* - z^* C_0^*$ and where I_0^* denotes the identity on $T\omega_0^*$.

Thus, the boundary condition $\overline{\mathcal{H}^*} n_0 = 0$ on Γ_0^{2*} can be written as :

$$(2.3) \quad \mathcal{H}^* \Pi_0 \kappa_0^{*-1} \nu_0 = 0 \quad \text{on } \Gamma_0^{2*}.$$

In the case of strongly curved shells, it is not necessary to decompose completely the equilibrium Eqs. (2.1) onto $T\omega_0^* \oplus \mathbb{R}N_0$ as in the first part. To simplify the calculations, we will use only a partial decomposition. To do this, we introduce the two-dimensional divergence $\text{div}_{t_3}^*$ defined as follows³⁾:

Let A be an operator field defined on ω_0^* which takes its values in $\mathcal{L}(\mathbb{R}^3, T\omega_0^*)$. Let us set $\mathcal{A}_t = A\Pi_0$ and $\mathcal{A}_s = AN_0$. Then we have :

$$\text{div}_{t_3}^*(\mathcal{A}) = \text{div}^*(\mathcal{A}_t) - \overline{\mathcal{A}_s} C_0^* + (\text{div}^*(\mathcal{A}_s) + \text{Tr}(\mathcal{A}_t C_0^*)) \overline{N_0}$$

where div^* denotes the two-dimensional divergence on ω_0^* .

³⁾This definition is similar to the one introduced in [25] by the author.

Thus, if we partially decompose \mathcal{H}^* as follows : $\mathcal{H}^* = \Pi_0 \mathcal{H}^* + N_0 \overline{N_0} \mathcal{H}^*$, the equilibrium Eq. (2.1) can be written :

$$(2.4) \quad \left\{ \begin{array}{l} \operatorname{div}_{t3}^*(\kappa_0^{*-1} \Pi_0 \mathcal{H}^*) - \operatorname{div}^*(\kappa^{*-1}) \Pi_0 \mathcal{H}^* \\ \qquad \qquad \qquad - \operatorname{Tr}(\kappa_0^{*-1} C_0^*) \overline{N_0} \mathcal{H}^* + \frac{\partial \overline{N_0} \mathcal{H}^*}{\partial z^*} = -\overline{f^*} \quad \text{in } \Omega_0^*, \\ \overline{\mathcal{H}^*}^\pm N_0 = \pm g^{*\pm} \quad \text{on } \Gamma_0^{*\pm}, \\ \phi^* = i_d \quad \text{on } \Gamma_0^{1*}, \\ \overline{\mathcal{H}^*} \Pi_0 \kappa_0^{*-1} \nu_0 = 0 \quad \text{on } \Gamma_0^{2*}. \end{array} \right.$$

3. Dimensional analysis and one-scale problem

As in the first part, we define the following dimensionless physical data and unknowns of the problem :

$$(3.1) \quad \begin{array}{l} p_0 = \frac{p_0^*}{L_0}, \quad q_0 = \frac{q_0^*}{L_0}, \quad \phi = \frac{\phi^*}{\phi_r}, \quad U = \frac{U^*}{U_r}, \quad z = \frac{z^*}{h_0}, \\ C_0 = \frac{C_0^*}{C_r}, \quad f_n = \frac{f_t^*}{f_{tr}}, \quad g_n = \frac{f_n^*}{f_{nr}}, \quad g_n = \frac{g_t^*}{g_{tr}}, \quad g_t = \frac{g_n^*}{g_{nr}}, \end{array}$$

where the variables with subscript r are the reference ones. The new variables which appear without an asterisk are dimensionless. To avoid any assumptions concerning the order of magnitude of the displacements, the reference scales ϕ_r and U_r are firstly assumed to be equal to L_0 . If necessary, it will always be possible to define new reference scales for the displacement.

On the other hand, we will use as in the first part, the following notations to simplify the calculations :

$$(3.2) \quad F = \varepsilon F^*, \quad E = \varepsilon^2 E^*, \quad \Sigma = \frac{\varepsilon^2}{\mu} \Sigma^* \quad \text{and} \quad \mathcal{H} = \frac{\varepsilon^3}{\mu} \mathcal{H}^*.$$

Then the dimensionless expressions of F , E , Σ and \mathcal{H} are given by:

$$(3.3) \quad F = \varepsilon \frac{\partial \phi}{\partial p_0} \kappa_0^{-1} + \frac{\partial \phi}{\partial z} \overline{N_0}.$$

$$(3.4) \quad 2E = \overline{F} F - \varepsilon^2 I_3, \quad \Sigma = \beta \operatorname{Tr}(E) I_3 + 2E, \quad \mathcal{H} = \beta \operatorname{Tr}(E) \overline{F} + 2E \overline{F}$$

and can be calculated from the mapping ϕ .

With these notations, the dimensional analysis of Eq. (2.4) leads to the dimensionless equilibrium equations:

$$\begin{aligned}
 \varepsilon \operatorname{div}_{t3}(\kappa_0^{-1} \Pi_0 \mathcal{H}) - \varepsilon \operatorname{div}(\kappa_0^{-1}) \Pi_0 \mathcal{H} - C \operatorname{Tr}(\kappa_0^{-1} C_0) \overline{N}_0 \mathcal{H} + \frac{\partial \overline{N}_0 \mathcal{H}}{\partial z} \\
 = -\varepsilon^3 \mathcal{F} \bar{f} \quad \text{in} \quad \Omega_0, \\
 \overline{\mathcal{H}}^\pm N_0 = \pm \varepsilon^3 \mathcal{G} g \quad \text{on} \quad \Gamma_0^\pm, \\
 \phi = i_d \quad \text{on} \quad \Gamma_0^1, \\
 \overline{\mathcal{H}} \Pi_0 \kappa_0^{-1} \nu_0 = 0 \quad \text{on} \quad \Gamma_0^2,
 \end{aligned}
 \tag{3.5}$$

and naturally introduces the same dimensionless numbers ε , C , \mathcal{F} and \mathcal{G} as for shallow shells [10]. We recall that the two shape factors $\varepsilon = \frac{h_0}{L_0}$ and $C = h_0 C_r$ characterize the geometry of the shell (relative thickness and curvature), whereas the force ratios $\mathcal{F} = \mathcal{F}_t = \mathcal{F}_n = \frac{h_0 f_{tr}}{\mu} = \frac{h_0 f_{nr}}{\mu}$ and $\mathcal{G} = \mathcal{G}_t = \mathcal{G}_n = \frac{g_{tr}}{\mu} = \frac{g_{nr}}{\mu}$ characterize the forces applied to the shell⁴).

To apply the standard technique of asymptotic expansions, the problem must be reduced to a one-scale problem. To do this, ε is chosen as the reference perturbation parameter and the other dimensionless numbers must be linked to ε . In the first part of this paper, we have studied shallow shells which correspond to $C = \varepsilon^2$. In the second part, we will consider strongly curved shells for which $C = \varepsilon$.

On the other hand, as in the first part, the study of all the force levels can be reduced without loss of generality to the particular choices $\mathcal{F}_t = \mathcal{G}_t$ and $\mathcal{F}_n = \mathcal{G}_n$. Moreover, as in the case of strongly curved shells the tangential and the normal direction play a symmetrical role, we will only consider force levels such as $\mathcal{F}_t = \mathcal{F}_n = \mathcal{G}_t = \mathcal{G}_n$. However, to separate body forces from surface forces in the equations, we have set $\mathcal{F} = \mathcal{F}_t = \mathcal{F}_n$ and $\mathcal{G} = \mathcal{G}_t = \mathcal{G}_n$, even if we always consider force levels such as $\mathcal{F} = \mathcal{G}$.

Finally, the classification of asymptotic shell models will be deduced for decreasing force levels, from severe ($\mathcal{F} = \mathcal{G} = \varepsilon$) to low ($\mathcal{F} = \mathcal{G} = \varepsilon^{n \geq 4}$).

⁴More precisely, \mathcal{F}_t and \mathcal{F}_n (respectively \mathcal{G}_t and \mathcal{G}_n) represent the ratio of the resultant on the thickness of the body forces (respectively the ratio of the surface forces) to μ considered as a reference stress.

4. The nonlinear membrane model

In this section, we begin the classification with severe force levels. We will show that the asymptotic expansion of equations naturally leads to the nonlinear membrane model.

4.1. Asymptotic expansion of equations

We consider a strongly curved shell ($C = \varepsilon$) subjected to a severe force level $\mathcal{G} = \mathcal{F} = \varepsilon$. Once reduced to a one-scale problem, we postulate that the displacement U or equivalently, the mapping $\phi = i_d + U$ admits a formal expansion with respect to ε :

$$U = U^0 + \varepsilon U^1 + \varepsilon^2 U^2 + \dots$$

$$\phi = \phi^0 + \varepsilon \phi^1 + \varepsilon^2 \phi^2 + \dots$$

with $\phi^0 = i_{\omega_0} + U^0$, $\phi^1 = U^1 + zN_0$ and $\phi^i = U^i$ for $i \geq 2$. If necessary, it will be possible to decompose U into $T\omega_0 \oplus \mathbb{R}N$ as follows : $U = V + uN_0$.

The expansion of ϕ implies via (3.3) and (3.4) an expansion of F , E , Σ and \mathcal{H} whose terms will be calculated when necessary. Let us just notice that we now have :

$$\kappa^{-1} = (I_0 - \varepsilon z C_0)^{-1} = I_0 + z\varepsilon C_0^1 + z^2 \varepsilon^2 C_0^2 + \dots$$

Then the asymptotic expansion of equations leads to the following result:

RESULT 1.

For applied forces such as $\mathcal{G} = \mathcal{F} = \varepsilon$, the leading term ϕ^0 of the expansion of ϕ depends only on p_0 and is a solution of the following nonlinear membrane model:

$$\operatorname{div}_{t3} \left(n_t^0 \frac{\partial \phi^0}{\partial p_0} \right) = -\bar{p} \quad \text{in } \omega_0,$$

$$\phi^0 = i_{\omega_0} \quad \text{on } \gamma_0^1,$$

$$n_t^0 \nu_0 = 0 \quad \text{on } \gamma_0^2$$

where ν_0 denotes the unit external normal to γ_0 and where

$$n_t^0 = \frac{4\beta}{2 + \beta} \operatorname{Tr}(\Delta_t^0) I_0 + 4\Delta_t^0, \quad 2\Delta_t^0 = \frac{\partial \phi^0}{\partial p_0} \frac{\partial \phi^0}{\partial p_0} - I_0 \quad \text{and} \quad p = g^+ + g^- + \int_{-1}^{+1} f dz.$$

P r o o f. The proof of this result is similar to the one of the nonlinear membrane model of the first part of this paper [10]. Let us just recall the intermediate

results which will be used in what follows. On one hand, the second term ϕ^1 of the expansion on ϕ can be written as:

$$(4.1) \quad \phi^1 = U^1(p_0) + z\theta_0 N \quad \text{with} \quad \theta_0 = \sqrt{1 - \frac{2\beta}{\beta + 2} \text{Tr}(\Delta_t^0)}$$

where N denotes the unit vector orthogonal to the surface $\omega = \phi^0(\omega_0)$ oriented so as θ_0 to be positive. On the other hand, according to (3.3)–(3.4), we get :

$$(4.2) \quad F^1 = \theta^0 N \overline{N_0} + \frac{\partial \phi^0}{\partial p_0}.$$

□

4.2. Comparison with existing results

To compare the nonlinear membrane model obtained in Result 1 to other existing models, we must explain its associated weak formulation. To do this, let us define the space of admissible displacements :

$$V(\omega_0) = \left\{ U : \omega_0 \rightarrow \mathbb{R}^3, \text{ "smooth", } U = 0 \text{ on } \gamma_0^1 \right\}$$

and the space of admissible mappings :

$$Q(\omega_0) = \left\{ \phi : \omega_0 \rightarrow \mathbb{R}^3, \text{ "smooth", } \phi = i_{\omega_0} \text{ on } \gamma_0^1 \right\}$$

Then the two-dimensional equations of Result 1 can be written in the following weak formulation:

RESULT 2.

The mapping $\phi^0 \in Q(\omega_0)$ satisfies the following weak problem :

$$(4.3) \quad \int_{\omega_0} \text{Tr} (n_t^0 \delta \Delta_t^0) d\omega_0 = \int_{\omega_0} \bar{p} \delta \phi^0 d\omega_0, \quad \forall \delta \phi^0 \in V(\omega_0)$$

with

$$n_t^0 = \frac{4\beta}{2 + \beta} \text{Tr} (\Delta_t^0) I_0 + 4\Delta_t^0, \quad 2\Delta_t^0 = \frac{\partial \phi^0}{\partial p_0} \frac{\partial \phi^0}{\partial p_0} - I_0,$$

where $\delta \Delta_t^0$ denotes the virtual variation of Δ_t^0 due to the virtual displacement $\delta \phi^0$ associated to ϕ^0 .

The proof of this result is classical and is based on the Stokes formula. It will not be detailed here. Let us notice that the non-linear membrane model has been also deduced by asymptotic expansion in [13] using a description of the shell in local coordinates. The equations obtained are the same as the ones of Result 2.

5. Non-inhibited shells in the nonlinear range

5.1. Nonlinear model coupling membrane-bending effects

In this section, we consider a shell non-inhibited in the nonlinear range subjected to a high force level of ε^2 order. First, using the previous results, we will specify the expressions of ϕ^0 and ϕ^1 . Then we will continue the asymptotic expansion of the equilibrium Eq. (3.5).

5.1.1. Characterization of ϕ^0 . For a level force such as $\mathcal{G} = \mathcal{F} = \varepsilon^2$, the Results 1 and 2 are still valid. We then obtain the same nonlinear membrane model without a right-hand side with the following associated minimization problem:

Find ϕ^0 which minimizes the functional $\mathcal{J} = \int_{\omega_0} \alpha d\omega_0$ on $Q(\omega_0)$, where

$$\alpha = \frac{2\beta}{\beta + 2} \text{Tr}(\Delta)^2 + 2\text{Tr}[(\Delta)^2] \quad \text{and} \quad 2\Delta = \frac{\overline{\partial\phi}}{\partial\phi} \frac{\partial\phi^0}{\partial p_0} - I_0.$$

As the density of energy α is positive and is equal to zero if and only if $\Delta = 0$, the solutions ϕ^0 of this minimization problem satisfy $\Delta = 0$ or equivalently:

$$(5.1) \quad \frac{\overline{\partial\phi^0}}{\partial p_0} \frac{\partial\phi^0}{\partial p_0} = I_0.$$

As the shell is assumed to be non-inhibited, Eq. (5.1) admits other solutions as rigid mappings. Let us denote by $I_{\text{inex}}(\omega_0)$ the space of inextensional mappings:

$$(5.2) \quad I_{\text{inex}}(\omega_0) = \left\{ \phi : \omega_0 \rightarrow \mathbb{R}^3, \text{ "smooth", } \frac{\overline{\partial\phi}}{\partial p_0} \frac{\partial\phi}{\partial p_0} = I_0 \text{ in } \omega_0, \phi = i_{\omega_0} \text{ on } \gamma_0^1 \right\}$$

Thus we have $\phi^0 \in I_{\text{inex}}(\omega_0)$ and the expression (4.1) of ϕ^1 then becomes:

$$(5.3) \quad \phi^1 = U^1(p_0) + zN$$

In the same way, the expression (4.2) of F^1 reduces to:

$$(5.4) \quad F^1 = \frac{\partial\phi^0}{\partial p_0} + N\overline{N_0}$$

which implies that $\overline{F^1}F^1 = I_0 + N_0\overline{N_0} = I_3$. On the other hand, the expansion of the equation of continuity⁵⁾ $\det F^* \geq a > 0$ in Ω_0^* leads to $\det F^1 > 0$. Thus

⁵⁾See condition (2) in the first part [10].

F^1 is a rotation of \mathbb{R}^3 and we have :

$$\overline{F^1} F^1 = F^1 \overline{F^1} = I_3 \quad \text{and} \quad (F^1)^{-1} = \overline{F^1}.$$

Then replacing the expression (5.4) of F^1 in $F^1 \overline{F^1} = I_3$, we get:

$$(5.5) \quad \frac{\partial \phi^0}{\partial p_0} \frac{\partial \overline{\phi^0}}{\partial p_0} + N \overline{N} = I_3.$$

Using the decomposition $I_3 = I + N \overline{N}$ on $T\omega \oplus \mathbb{R}N$, where $\omega = \phi^0(\omega_0)$ and I denotes the identity on $T\omega$, we obtain

$$(5.6) \quad \frac{\partial \phi^0}{\partial p_0} \frac{\partial \overline{\phi^0}}{\partial p_0} = I.$$

This relation will be used later to simplify the calculations.

Finally, using (3.3), (3.4), (5.1) and (5.3), we can calculate the first non-zero terms of the expansions of F , E , Σ and \mathcal{H} . On the one hand F^1 is given by (5.4), and on the other hand we have :

$$(5.7) \quad \begin{aligned} F^2 &= \frac{\partial \phi^2}{\partial z} \overline{N}_0 + \frac{\partial U^1}{\partial p_0} - z \frac{\partial \phi^0}{\partial p_0} K_t^0, & 2E^3 &= \overline{F^1} F^2 + \overline{F^2} F^1, \\ \Sigma^3 &= \beta \text{Tr}(E^3) I_3 + 2E^3, & \mathcal{H}^4 &= \Sigma^3 \overline{F^1}, \end{aligned}$$

with $K_t^0 = \tilde{C} - C_0$ and where $\tilde{C} = -\frac{\partial \overline{\phi^0}}{\partial p_0} \frac{\partial N}{\partial p_0} = -\frac{\partial \overline{\phi^0}}{\partial p_0} C \frac{\partial \phi^0}{\partial p_0}$ denotes the pull-back on ω_0 of the curvature operator C of the surface $\omega = \phi^0(\omega_0)$. Here $K_t^0 = \tilde{C} - C_0$ represents the classical nonlinear change of curvature.

5.1.2. Asymptotic expansion. Taking into account (5.1), we continue the asymptotic expansion of equations. We then have the following result:

RESULT 3.

For a non-inhibited shell in the nonlinear range, subjected to a high level of forces $\mathcal{G} = \mathcal{F} = \varepsilon^2$, the leading terms ϕ^0 and ϕ^1 of the expansion of ϕ satisfy:

- i) ϕ^0 depends only on p_0 and $\phi^0 \in I_{\text{inex}}(\omega_0)$.
- ii) $\phi^1 = U^1 + zN$, where U^1 depends only on p_0 and N denotes the normal to the deformed configuration $\phi^0(\omega_0)$.
- iii) ϕ^0 and U^1 are solutions of the following nonlinear equations:

$$\text{and } \begin{cases} \operatorname{div}_{t3} \left(n_t^1 \frac{\overline{\partial \phi^0}}{\partial p_0} \right) = -\bar{p} & \text{in } \omega_0 \\ U^1 = 0 & \text{on } \gamma_0^1 \\ n_t^1 \nu_0 = 0 & \text{on } \gamma_0^2 \end{cases}$$

$$\begin{cases} \operatorname{div}_{t3} \left((\chi - C_0 m_t^0) \frac{\overline{\partial \phi^0}}{\partial p_0} + n_t^1 \frac{\overline{\partial U^1}}{\partial p_0} - \overline{\operatorname{div}(m_t^0)N} \right) = -\bar{P} & \text{in } \omega_0 \\ \phi^0 - i_{\omega_0} = \Theta^0 = 0 & \text{on } \gamma_0^1 \\ \chi \nu_0 - m_t^0 C_0 \nu_0 = m_t^0 \nu_0 = \bar{M} \frac{\overline{\partial \phi^0}}{\partial p_0} \nu_0 - \operatorname{div}(m_t^0) \nu_0 = 0 & \text{on } \gamma_0^2 \end{cases}$$

where χ is a field of symmetrical tensors which depends only on ϕ^0, ϕ^1 and ϕ^2 , and where:

$$\begin{aligned} n_t^1 &= \frac{4\beta}{2+\beta} \operatorname{Tr}(\Delta_t^1) I_0 + 4\Delta_t^1, & 2\Delta_t^1 &= \frac{\overline{\partial \phi^0}}{\partial p_0} \frac{\partial U^1}{\partial p_0} + \frac{\overline{\partial U^1}}{\partial p_0} \frac{\partial \phi^0}{\partial p_0}, \\ m_t^0 &= \frac{4\beta}{3(\beta+2)} \operatorname{Tr}(K_t^0) I_0 + \frac{4}{3} K_t^0, & K_t^0 &= \tilde{C} - C_0, \\ \tilde{C} &= -\frac{\overline{\partial \phi^0}}{\partial p_0} \frac{\partial N}{\partial p_0}, & \Theta^0 &= -\frac{\overline{\partial \phi^0}}{\partial p_0} N_0, \\ p &= g^+ + g^- + \int_{-1}^1 f \, dz, & M &= g^+ - g^- + \int_{-1}^1 z f \, dz, \\ P &= \overline{\operatorname{div}_{t3}} \left(\frac{\overline{\partial \phi^0}}{\partial p_0} M \bar{N} \right) - \operatorname{Tr}(C_0) M. \end{aligned}$$

Before giving the proof of this result which is rather technical, let us notice that the model obtained here is not easy to interpret in this local formulation. Contrary to the asymptotic models previously obtained, this one takes into account the two unknowns ϕ^0 and U^1 , where ϕ^0 is an inextensional mapping generating the curvature variation K_t^0 , and U^1 is a displacement generating the membrane strain Δ_t^1 .

On the other hand, let us remark that the expression of the field of symmetrical tensors χ , which is complex and depends on ϕ^0, ϕ^1 and ϕ^2 , is not given explicitly. It is not necessary because it will vanish in the associated weak formulation which is given in the next result. For an interpretation of this model the reader can be referred to Result 4.

P r o o f. The proof can be split into five steps, from i) to v).

i) *Determination of ϕ^2*

Problem \mathcal{P}^4 reduces to:

$$\begin{aligned} \frac{\partial \overline{\mathcal{H}^4 N^0}}{\partial z} &= 0 \quad \text{in } \Omega_0, \\ \overline{\mathcal{H}^4}^\pm N^0 &= 0 \quad \text{on } \Gamma_0^\pm, \end{aligned}$$

which leads to $\overline{\mathcal{H}^4} N^0 = 0$ in Ω_0 . Using (5.6) we get $F^1 \Sigma^3 N_0 = 0$ or equivalently

$$(5.8) \quad \Sigma^3 N_0 = 0 \quad \text{in } \Omega_0$$

because F^1 is invertible.

Then replacing Σ^3 by its expression (5.7), Eq. (5.8) becomes:

$$\left[(\beta + 2) \overline{N} \frac{\partial \phi^2}{\partial z} + \beta \operatorname{Tr}(\Delta_t^1 - z K_t^0) \right] N_0 + \frac{\partial \overline{U^1}}{\partial p_0} N_0 \frac{\partial \phi^0}{\partial p_0} \frac{\partial \phi^2}{\partial z} = 0$$

$$\text{where } 2\Delta_t^1 = \frac{\partial \overline{\phi^0}}{\partial p_0} \frac{\partial U^1}{\partial p_0} + \frac{\partial \overline{U^1}}{\partial p_0} \frac{\partial \phi^0}{\partial p_0}.$$

Now, let us project the last equation onto $T\omega_0$ and N_0 . We get:

$$\frac{\partial \overline{\phi^0}}{\partial p_0} \frac{\partial \phi^2}{\partial z} = -\frac{\partial \overline{U^1}}{\partial p_0} N \quad \text{and} \quad \overline{N} \frac{\partial \phi^2}{\partial z} - \frac{\beta}{\beta + 2} \operatorname{Tr}(\Delta_t^1 - z K_t^0)$$

or equivalently, using (5.6):

$$(5.9) \quad I \frac{\partial \phi^2}{\partial z} = \frac{\partial \phi^0}{\partial p_0} \frac{\partial \overline{U^1}}{\partial p_0} N \quad \text{and} \quad \overline{N} \frac{\partial \phi^2}{\partial z} = -\frac{\beta}{\beta + 2} \operatorname{Tr}(\Delta_t^1 - z K_t^0).$$

As $I + N\overline{N} = I_3$, the two Eq. (5.9) are the projections onto $T\omega$ and N of the vector $\frac{\partial \phi^2}{\partial z}$.

Then we have:

$$(5.10) \quad \frac{\partial \phi^2}{\partial z} = -\frac{\partial \phi^0}{\partial p_0} \frac{\partial \overline{U^1}}{\partial p_0} N - \frac{\beta}{\beta + 2} \operatorname{Tr}(\Delta_t^1 - z K_t^0) N.$$

A integration with respect to z then leads to the following expression of ϕ^2 :

$$(5.11) \quad \phi^2 = \underline{U}^2 - z \frac{\partial \phi^0}{\partial p_0} \frac{\partial \overline{U^1}}{\partial p_0} N - z \frac{\beta}{2(\beta + 2)} \operatorname{Tr}(2\Delta_t^1 - z K_t^0) N.$$

where \underline{U}^2 depends only on p_0 .

Now let us calculate the expressions of E^3 , Σ^3 and \mathcal{H}^4 . First, using (5.11), the expression (5.7) of F^2 becomes:

$$(5.12) \quad F^2 = -\frac{\partial\phi^0}{\partial p_0} \frac{\partial U^1}{\partial p_0} N\overline{N}_0 + \frac{\partial U^1}{\partial p_0} - z \frac{\partial\phi^0}{\partial p_0} K_t^0 - \frac{\beta}{\beta+2} \text{Tr}(\Delta_t^1 - zK_t^0) N\overline{N}_0.$$

Then multiplying the last equation by $\overline{F^1}$, and using the relations

$$F^1 = \frac{\partial\phi^0}{\partial p_0} + N\overline{N}_0, \quad \overline{\frac{\partial\phi^0}{\partial p_0}} \frac{\partial\phi^0}{\partial p_0} = I_0 \quad \text{and} \quad \overline{N} \frac{\partial\phi^0}{\partial p_0} = 0,$$

we get:

$$\overline{F^1} F^2 = -\frac{\overline{\partial U^1}}{\partial p_0} N\overline{N}_0 + N_0 \overline{N} \frac{\partial U^1}{\partial p_0} + \overline{\frac{\partial\phi^0}{\partial p_0}} \frac{\partial U^1}{\partial p_0} - zK_t^0 - \frac{\beta}{\beta+2} \text{Tr}(\Delta_t^1 - zK_t^0) N_0 \overline{N}_0.$$

Finally, in view of (5.7), E^3 , Σ^3 and \mathcal{H}^4 can be expressed as follows :

$$(5.13) \quad \begin{aligned} E^3 &= \Delta_t^1 - zK_t^0 - \frac{\beta}{\beta+2} \text{Tr}(\Delta_t^1 - zK_t^0) N_0 \overline{N}_0, \\ \Sigma^3 &= \frac{1}{2}(n_t^1 - 3zm_t^0), \\ \mathcal{H}^4 &= \frac{1}{2}(n_t^1 - 3zm_t^0) \overline{\frac{\partial\phi^0}{\partial p_0}}, \end{aligned}$$

where $n_t^1 = \frac{4\beta}{\beta+2} \text{Tr}(\Delta_t^1) I_0 + 4\Delta_t^1$ and $m_t^0 = \frac{4\beta}{3(\beta+2)} \text{Tr}(K_t^0) I_0 + \frac{4}{3} K_t^0$.

ii) *First equation of Result 3*

In view of (5.13), the cancellation of the factor of ε^5 in the expansion of equilibrium Eq. (3.5) leads to problem \mathcal{P}^5 which reduces to:

$$\begin{aligned} \text{div}_{t3}(\Pi_0 \mathcal{H}^4) + \frac{\partial \overline{N}_0 \mathcal{H}^5}{\partial z} &= -\overline{f} \quad \text{in } \Omega_0, \\ \overline{\mathcal{H}^5}^\pm N_0 &= \pm g^\pm \quad \text{on } \Gamma_0^\pm, \end{aligned}$$

Using (5.13) we get:

$$(5.14) \quad \begin{aligned} \frac{1}{2} \text{div}_{t3} \left(n_t^1 \overline{\frac{\partial\phi^0}{\partial p_0}} \right) - \frac{3}{2} z \text{div}_{t3} \left(m_t^0 \overline{\frac{\partial\phi^0}{\partial p_0}} \right) + \frac{\partial \overline{N}_0 \mathcal{H}^5}{\partial z} &= -\overline{f} \quad \text{in } \Omega_0. \\ \overline{\mathcal{H}^5}^\pm N_0 &= \pm g^\pm \quad \text{on } \Gamma_0^\pm. \end{aligned}$$

Let us integrate the above equation upon the thickness. We then obtain:

$$\operatorname{div}_{t3} \left(n_t^1 \frac{\overline{\partial U^1}}{\partial p_0} \right) = -\bar{p} \quad \text{in } \omega_0$$

where $p = g^+ + g^- + \int_{-1}^1 f \, dz$, which constitutes the first equation of Result 3.

On the other hand, an integration of (5.14) with respect to z leads to:

$$(5.15) \quad 2\bar{N}_0 \mathcal{H}^5 = z\bar{p} + \overline{g^+} - \overline{g^-} + \int_z^1 \bar{f} \, dz - \int_{-1}^z \bar{f} \, dz - \frac{3}{2}(1-z^2) \operatorname{div}_{t3} \left(m_t^0 \frac{\overline{\partial \phi^0}}{\partial p_0} \right).$$

In what follows, to simplify the calculations, we set:

$$(5.16) \quad \begin{aligned} \bar{A} &= \bar{N}_0 \mathcal{H}^5 \\ &= \frac{1}{2} \left(z\bar{p} + \overline{g^+} - \overline{g^-} + \int_z^1 \bar{f} \, dz - \int_{-1}^z \bar{f} \, dz - \frac{3}{2}(1-z^2) \operatorname{div}_{t3} \left(m_t^0 \frac{\overline{\partial \phi^0}}{\partial p_0} \right) \right). \end{aligned}$$

iii) Computation of \mathcal{H}^5 :

Before writing problem \mathcal{P}^6 , let us decompose \mathcal{H}^5 as follows:

$$(5.17) \quad \mathcal{H}^5 = \Pi_0 \mathcal{H}^5 + N_0 \bar{N}_0 \mathcal{H}^5 = \Pi_0 \mathcal{H}^5 + N_0 \bar{A}$$

according to (5.16). On the other hand, the expression of \mathcal{H}^5 reduces to:

$$(5.18) \quad \mathcal{H}^5 = \Sigma^4 \bar{F}^1 + \Sigma^3 \bar{F}^2$$

and Eq. (5.17) can be written as:

$$\mathcal{H}^5 = \Pi_0 \Sigma^4 \bar{F}^1 + \Pi_0 \Sigma^3 \bar{F}^2 + N_0 \bar{A}.$$

Now, let us decompose also Σ^4 and Σ^3 as follows : $\Sigma^4 = \Sigma^4 \Pi_0 + \Sigma^4 N_0 \bar{N}_0$ and $\Sigma^3 = \Sigma^3 \Pi_0 + \Sigma^3 N_0 \bar{N}_0$. Then using (5.4), (5.8) and (5.12), the expression of \mathcal{H}^5 becomes:

$$(5.19) \quad \mathcal{H}^5 = \Pi_0 \Sigma^4 \Pi_0 \frac{\overline{\partial \phi^0}}{\partial p_0} + \Pi_0 \Sigma^4 N_0 \bar{N} + \Pi_0 \Sigma^3 \Pi_0 \left(\frac{\overline{\partial U^1}}{\partial p_0} - z K_t^0 \frac{\overline{\partial \phi^0}}{\partial p_0} \right) + N_0 \bar{A}.$$

On the other hand, let us multiply (5.18) by \overline{N}_0 on the left and by $\frac{\partial \phi^0}{\partial p_0}$ on the right. Using (5.4) and (5.8), we get $\overline{N}_0 \Sigma^4 \Pi_0 = \overline{A} \frac{\partial \phi^0}{\partial p_0}$ or equivalently

$$(5.20) \quad \Pi_0 \Sigma^4 N_0 = \frac{\overline{\partial \phi^0}}{\partial p_0} A$$

because Σ^4 is symmetrical.

Finally, in view of (5.8), (5.13) and (5.20), the expression (5.19) of \mathcal{H}^5 becomes:

$$(5.21) \quad \mathcal{H}^5 = \Pi_0 \Sigma^4 \Pi_0 \frac{\overline{\partial \phi^0}}{\partial p_0} + \frac{\overline{\partial \phi^0}}{\partial p_0} A \overline{N} + \frac{1}{2} (n_t^1 - 3z m_t^0) \left(\frac{\overline{\partial U^1}}{\partial p_0} - z K_t^0 \frac{\overline{\partial \phi^0}}{\partial p_0} \right) + N_0 \overline{A}.$$

Let us notice that the calculation of $\Pi_0 \Sigma^4 \Pi_0$ with respect to the displacements is not necessary. As already noticed, this term will vanish in the weak associated formulation.

iv) Second equation of Result 3

Problem \mathcal{P}^6 can be written as:

$$(5.22) \quad \begin{aligned} \operatorname{div}_{t3}(\Pi_0 \mathcal{H}^5 + z C_0 \mathcal{H}^4) - \operatorname{Tr}(C_0) \overline{N}_0 \mathcal{H}^5 - z \operatorname{div}(C_0) \Pi_0 \mathcal{H}^4 \\ + \frac{\partial \overline{N}_0 \mathcal{H}^6}{\partial z} = 0 \quad \text{in } \Omega_0, \end{aligned}$$

$$\overline{\mathcal{H}^6}^\pm N_0 = 0 \quad \text{on } \Gamma_0^\pm.$$

Using the expressions (5.13) and (5.21) of \mathcal{H}^4 and \mathcal{H}^5 , an integration upon the thickness of Eq. (5.22) leads to:

$$(5.23) \quad \begin{aligned} \operatorname{div}_{t3} \left[\tilde{\chi} \frac{\overline{\partial \phi^0}}{\partial p_0} + n_t^1 \frac{\overline{\partial U^1}}{\partial p_0} - \frac{\overline{\partial \phi^0}}{\partial p_0} \operatorname{div}_{t3} \left(m_t^0 \frac{\overline{\partial \phi^0}}{\partial p_0} \right) \overline{N} - C_0 m_t^0 \frac{\overline{\partial \phi^0}}{\partial p_0} \right] \\ + \operatorname{Tr}(C_0) \operatorname{div}_{t3} \left[m_t^0 \frac{\overline{\partial \phi^0}}{\partial p_0} \right] + \operatorname{div}(C_0) m_t^0 \frac{\overline{\partial \phi^0}}{\partial p_0} = -\overline{P} \quad \text{in } \omega_0 \end{aligned}$$

where the expressions of P and M are those of Result 3 and where

$$\tilde{\chi} = \int_{-1}^1 \Pi_0 \Sigma^4 \Pi_0 dz + m_t^0 K_t^0.$$

In the last expression, $\tilde{\chi}$ is symmetrical because m_t^0 and K_t^0 are symmetrical and commute.

Now using the following property

$$\text{Tr}(C_0) \text{div}_{t3} \left(m_t^0 \frac{\overline{\partial \phi^0}}{\partial p_0} \right) + \text{div}(C_0) m_t^0 \frac{\overline{\partial \phi^0}}{\partial p_0} = \text{div}_{t3} \left(\text{Tr}(C_0) m_t^0 \frac{\overline{\partial \phi^0}}{\partial p_0} \right),$$

Eq. (5.23) becomes:

$$(5.24) \quad \text{div}_{t3} \left[\left(\chi - C_0 m_t^0 \right) \frac{\overline{\partial \phi^0}}{\partial p_0} + n_t^1 \frac{\overline{\partial U^1}}{\partial p_0} - \frac{\overline{\partial \phi^0}}{\partial p_0} \text{div}_{t3} \left(m_t^0 \frac{\overline{\partial \phi^0}}{\partial p_0} \right) \overline{N} \right] = -\overline{P} \quad \text{in } \omega_0$$

with:

$$(5.25) \quad \chi = \tilde{\chi} + \text{Tr}(C_0) m_t^0 = \int_{-1}^1 \Pi_0 \Sigma^4 \Pi_0 dz + m_t^0 K_t^0 + \text{Tr}(C_0) m_t^0.$$

Let us just notice that χ is a field of symmetrical tensors.

Finally, as $\frac{\overline{\partial \phi^0}}{\partial p_0} \frac{\partial \phi^0}{\partial p_0} = I_0$, it is possible to prove that :

$$(5.26) \quad \text{div}_{t3} \left(m_t^0 \frac{\overline{\partial \phi^0}}{\partial p_0} \right) \frac{\partial \phi^0}{\partial p_0} = \text{div}(m_t^0)$$

where div denotes the classical two-dimensional divergence on ω_0 . Thus Eq. (5.24) constitutes the second equation of Result 3.

v) Boundary conditions

To conclude the proof, let us examine the boundary conditions. The expansion of the clamping condition $\phi(q_0) = q_0$ on Γ_0^1 leads to $U^0 = 0$, $U^1 = 0$ and $N = N_0$ on γ_0^1 . The last condition $N = N_0$ can also be written $\Theta^0 = 0$ on γ_0^1 , where $\Theta^0 = -\frac{\overline{\partial \phi^0}}{\partial p_0} N_0$ characterizes the rotation of the normal N_0 to the middle surface ω_0 .

The boundary conditions on the portion γ_0^2 of the lateral surface γ_0 can be obtained formally from the three-dimensional boundary conditions as follows. As we have

$$\overline{\mathcal{H}} \kappa_0^{-1} \nu_0 = \varepsilon^4 \overline{\mathcal{H}^4} \nu_0 + \varepsilon^5 (z \overline{\mathcal{H}^4} C_0 + \overline{\mathcal{H}^5}) \nu_0 + \dots = 0 \quad \text{on } \Gamma_0^2,$$

using (5.13) and (5.21), we get:

$$(5.27) \quad \frac{\partial \phi^0}{\partial p_0} (n_t^1 \nu_0 - 3z m_t^0 \nu_0) = 0 \quad \text{on } \Gamma_0^2,$$

$$(5.27) \quad \frac{\partial \phi^0}{\partial p_0} \Pi_0 \Sigma^4 \Pi_0 \nu_0 + z \frac{\partial \phi^0}{\partial p_0} (n_t^1 - 3zm_t^0) C_0 \nu_0 + N \bar{A} \frac{\partial \phi^0}{\partial p_0} \nu_0 + \frac{1}{2} \left(\frac{\partial U^1}{\partial p_0} - z \frac{\partial \phi^0}{\partial p_0} K_t^0 \right) (n_t^1 - 3zm_t^0) \nu_0 = 0 \quad \text{on } \Gamma_0^2.$$

The first equation of (5.27) leads to:

$$(5.28) \quad n_t^1 \nu_0 = 0 \quad \text{and} \quad m_t^0 \nu_0 = 0 \quad \text{on } \gamma_0^2.$$

Now, multiplying the second equation of (5.27), on the one hand by $\frac{\partial \phi^0}{\partial p_0}$ and on the other hand by \bar{N} , using (5.1) and (5.28), we get:

$$\Pi_0 \Sigma^4 \Pi_0 \nu_0 + \frac{1}{2} z (n_t^1 - 3zm_t^0) C_0 \nu_0 = 0 \quad \text{and} \quad \bar{A} \frac{\partial \phi^0}{\partial p_0} \nu_0 = 0 \quad \text{on } \Gamma_0^2.$$

Then using (5.16), the integration upon the thickness of the above equations leads to:

$$(5.29) \quad \int_{-1}^1 \Pi_0 \Sigma^4 \Pi_0 \nu_0 \, dz - m_t^0 C_0 \nu_0 = 0 \quad \text{on } \gamma_0^2,$$

$$\bar{M} \frac{\partial \phi^0}{\partial p_0} \nu_0 - \text{div}_{t3} \left(m_t^0 \frac{\partial \phi^0}{\partial p_0} \right) \frac{\partial \phi^0}{\partial p_0} \nu_0 = 0 \quad \text{on } \gamma_0^2,$$

where $M = g^+ - g^- + \int_{-1}^1 z f \, dz$.

According to (5.25) and (5.28), the first equation of (5.29) becomes:

$$\chi \nu_0 - m_t^0 C_0 \nu_0 = 0.$$

Finally using (5.26), the second equation of (5.29) reduces to

$$\bar{M} \frac{\partial \phi^0}{\partial p_0} \nu_0 - \text{div} (m_t^0) \nu_0 = 0 \quad \text{on } \gamma_0^2$$

which concludes the proof of Result 3. □

5.1.3. Nonlinear model with coupling effects. The model obtained in Result 3 is not usable numerically. It contains three unknowns ϕ^0 , ϕ^1 and ϕ^2 coupled together in the tensor χ . However, its associated weak formulation enables to reduce the numbers of unknowns. Indeed, let us define the following admissible spaces of mappings and displacements :

$$V(\omega_0) = \{U : \omega_0 \rightarrow \mathbb{R}^3, \text{ "smooth", } U = 0 \text{ on } \gamma_0^1\},$$

$$(5.30) \quad V_{\text{inex}}^{\phi^0}(\omega_0) = \left\{ U \in V(\omega_0), \frac{\overline{\partial\phi^0}}{\partial p_0} \frac{\partial U}{\partial p_0} + \frac{\overline{\partial U}}{\partial p_0} \frac{\partial\phi^0}{\partial p_0} = 0 \text{ in } \omega_0 \right\},$$

$$Q_{\text{inex}}(\omega_0) = \left\{ \phi \in I_{\text{inex}}, \frac{\overline{\partial\phi}}{\partial p_0} N_0 = 0 \text{ on } \gamma_0^1 \right\},$$

where I_{inex} is defined by (5.2).

Thus, the two-dimensional equations of Result 3 can be written in the following weak formulation:

RESULT 4.

$(\phi^0, U^1) \in Q_{\text{inex}}(\omega_0) \times V(\omega_0)$ is solution of the weak problem:

$$\int_{\omega_0} \text{Tr} (n_t^1 \delta \Delta_t^1 + m_t^0 \delta K_t^0) d\omega_0 = \int_{\omega_0} (\bar{p} \delta U^1 - \text{Tr}(C_0) \bar{M} \delta \phi^0 + \bar{M} \delta N) d\omega_0$$

$$\forall (\delta \phi^0, \delta U^1) \in V_{\text{inex}}^{\phi^0}(\omega_0) \times V(\omega_0)$$

with:

$$n_t^1 = \frac{4\beta}{2+\beta} \text{Tr}(\Delta_t^1) I_0 + 4\Delta_t^1, \quad 2\Delta_t^1 = \frac{\overline{\partial\phi^0}}{\partial p_0} \frac{\partial U^1}{\partial p_0} + \frac{\overline{\partial U^1}}{\partial p_0} \frac{\partial\phi^0}{\partial p_0},$$

$$m_t^0 = \frac{4\beta}{3(\beta+2)} \text{Tr}(K_t^0) I_0 + \frac{4}{3} K_t^0, \quad K_t^0 = \tilde{C} - C_0 \quad \text{and} \quad \tilde{C} = -\frac{\overline{\partial\phi^0}}{\partial p_0} \frac{\partial N}{\partial p_0},$$

$$p = g^+ + g^- + \int_{-1}^1 f dz, \quad M = g^+ - g^- + \int_{-1}^1 z f dz.$$

The proof of this result is long and technical, hence will not be reported. It is based on the successive use of the Stokes formula. \square

5.1.4. Interpretation of this coupling model. In Result 4, we have obtained a two-dimensional shell model which couples membrane and bending effects. In this model, the resultant mapping of the middle surface of the shell is:

$$\tilde{\phi} = \phi^0 + \varepsilon U^1$$

and the resultant displacement of a point p_0 is represented in the following figure:

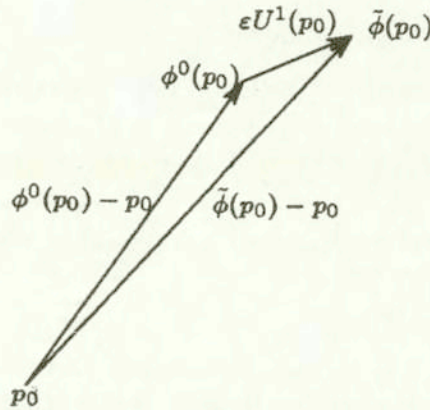

FIG. 2. Decomposition of the displacement at a material point p_0 of ω_0 .

Thus, the displacement can be split into:

- an inextensional mapping ϕ^0 .
- a small displacement εU^1 .

On the other hand, in the coupling model of Result 4, the unknowns ϕ^0 and U^1 generate two kind of strain :

- a nonlinear pure bending strain K_t^0 due to ϕ^0
- a membrane strain Δ_t^1 due to the displacement U^1 .

In fact, the strain Δ_t^1 can be written as

$$(5.31) \quad \Delta_t^1 = \overline{\frac{\partial \phi^0}{\partial p_0}} \Delta_{\phi^0}^1 \frac{\partial \phi^0}{\partial p_0}$$

where $\Delta_{\phi^0}^1 = \frac{1}{2} \left(\Pi \frac{\partial U^1}{\partial p} + \overline{\Pi \frac{\partial U^1}{\partial p}} \right)$ is the linear strain due to U^1 and calculated at the point $p = \phi^0(p_0)$ of the deformed surface $\phi^0(\omega_0)$. Thus Δ_t^1 corresponds to the pull-back on ω_0 of the linear strain $\Delta_{\phi^0}^1$ due to U^1 .

This coupled model is to our knowledge a new nonlinear shell model which couples membrane and bending effects. For a non-inhibited shell it is possible to prove formally that this model and the nonlinear Koiter's one have the same limit when ε tends towards zero. Thus, this new coupling model is an approximation of the nonlinear Koiter's one for non-inhibited shells. In the linear case, an asymptotic analysis of Koiter's model has been made in [19][20]. However, the only two models which are obtained are the linear membrane and the pure bending ones.

5.2. The nonlinear pure bending model

In this section we consider a shell, still inhibited in the nonlinear range, but subjected to a moderate force level $\mathcal{G} = \mathcal{F} = \varepsilon^3$. Then we prove that for this force level, the asymptotic expansion of equations leads to the classical nonlinear pure bending model.

We recall that the spaces $V_{\text{inex}}^{\phi^0}(\omega_0)$ and $Q_{\text{inex}}(\omega_0)$ are defined in (5.30). We then have the following result:

RESULT 5.

For a shell inhibited in the nonlinear range and subjected to a moderate force level $\mathcal{G} = \mathcal{F} = \varepsilon^3$, the leading term ϕ^0 of the expansion of the mapping ϕ depends only on p_0 and is solution of the nonlinear pure bending model:

$$\phi^0 \in Q_{\text{inex}}(\omega_0),$$

$$\int_{\omega_0} \text{Tr} (m_t^0 \delta K_t^0) d\omega_0 = \int_{\omega_0} \bar{p} \delta \phi^0 d\omega_0 \quad \forall \delta \phi^0 \in V_{\text{inex}}^{\phi^0}(\omega_0)$$

where:

$$m_t^0 = \frac{4\beta}{3(\beta+2)} \text{Tr} (K_t^0) I_0 + \frac{4}{3} K_t^0, \quad K_t^0 = \tilde{C} - C_0, \quad \tilde{C} = -\frac{\overline{\partial \phi^0}}{\partial p_0} \frac{\partial N}{\partial p_0},$$

$$p = \int_{-1}^{+1} f dz + g^+ + g^-,$$

and where N denotes the normal to the deformed configuration $\phi^0(\omega_0)$.

P r o o f. For the moderate force level considered here, following the proof of Result 4, we obtain the same weak formulation with $\int_{-1}^1 \bar{p} \delta \phi^0 d\omega_0$ as the right side:

$(\phi^0, U^1) \in Q_{\text{inex}}(\omega_0) \times V(\omega_0)$ satisfies:

$$(5.32) \quad \int_{\omega_0} \text{Tr} (n_t^1 \delta \Delta_t^1 + m_t^0 \delta K_t^0) d\omega_0 = \int_{\omega_0} \bar{p} \delta \phi^0 d\omega_0$$

$$\forall (\delta \phi^0, \delta U^1) \in V_{\text{inex}}^{\phi^0}(\omega_0) \times V(\omega_0).$$

Now, if we choose $\delta \phi^0 = 0$ in this weak formulation, we obtain

$$\int_{\omega_0} \text{Tr} (n_t^1 \delta \Delta_t^1) d\omega_0 = 0 \quad \forall \delta U^1 \in V(\omega_0),$$

which leads to

$$(5.33) \quad 2\Delta_t^1 = \frac{\overline{\partial \phi^0}}{\partial p_0} \frac{\partial U^1}{\partial p_0} + \frac{\overline{\partial U^1}}{\partial p_0} \frac{\partial \phi^0}{\partial p_0} = 0$$

according to the definition of n_t^1 (see Result 4). Finally, as $\Delta_t^1 = 0$ we have $n_t^1 = 0$ and the weak formulation (5.32) leads to the classical pure bending model. □

Thus we have justified the nonlinear pure bending model for a non-inhibited shell subjected to a moderate force level. The intrinsic approach used here makes clearly appear the curvature change $K_t^0 = \tilde{C} - C_0$, difference between the pull-back of the final curvature and the initial curvature. This nonlinear pure bending model has been justified also in [11] using a description of the middle surface of the shell in local coordinates. However, in this case the expression of K_t^0 which is obtained is difficult to interpret.

Finally let us notice that the existence of solutions of the pure bending model has recently been studied in [3]. However, the eventual uniqueness of the solution is still to be proved.

5.3. The linear pure bending model for linearly non-inhibited shells

We now consider a shell, still non-inhibited in the nonlinear range, but subjected to a low force level $\mathcal{G} = \mathcal{F} = \epsilon^4$. It is then necessary to distinguish the linearly non-inhibited from the linearly inhibited shells as well.

We will prove here that for linearly non-inhibited shells⁶⁾ subjected to the low force level considered here, the displacements are of the thickness order and the asymptotic model that we obtain is the linear pure bending one.

⁶⁾Still non-inhibited in the nonlinear range.

5.3.1. New reference scales for the displacement field. We begin to prove that the leading term U^0 of the expansion of the displacement vector is equal to zero. Indeed, for a low force level $\mathcal{G} = \mathcal{F} = \varepsilon^4$, we obtain the nonlinear pure bending model of Result 5 without a right side whose associated minimization problem is the following one:

Find ϕ^0 which minimizes in $Q_{inex}(\omega_0)$ the functional $\mathcal{J}(\phi) = \int_{\omega_0} \alpha \, d\omega_0$,
with

$$\alpha = \frac{2\beta}{3(\beta + 2)} \text{Tr}(K)^2 + \frac{2}{3} \text{Tr}(K^2), \quad K = \tilde{C} - C_0, \quad \tilde{C} = -\frac{\overline{\partial\phi}}{\partial p_0} \frac{\partial N}{\partial p_0},$$

where N denotes the unit normal to $\phi(\omega_0)$.

The solutions of this problem are the mappings ϕ^0 which satisfy

$$K_t^0 = \tilde{C} - C_0 = 0.$$

As ϕ^0 is an inextensional mapping which satisfies

$$\frac{\overline{\partial\phi^0}}{\partial p_0} \frac{\partial\phi^0}{\partial p_0} - I_0 = 0 \quad \text{in } \omega_0$$

the rigid motion lemma implies that $\phi^0 = i_{\omega_0}$. We have in particular $\frac{\partial\phi^0}{\partial p_0} = I_0$ and $N = N_0$. Thus, the leading term of the expansion of the displacement satisfies $U^0 = \phi^0 - i_{\omega_0} = 0$. Moreover, according to (5.11) and (5.33), we get:

$$(5.34) \quad \frac{\overline{\hat{\partial}U^1}}{\partial p_0} + \frac{\hat{\partial}U^1}{\partial p_0} = 0 \quad \text{and} \quad U^2 = \phi^2 = \underline{U}^2 - z \frac{\overline{\partial U^1}}{\partial p_0} N_0$$

where U^1 and \underline{U}^2 only depend on p_0 and where $\frac{\hat{\partial}}{\partial p_0} = \Pi_0 \frac{\partial}{\partial p_0}$ denotes the covariant derivative on ω_0 .

As we have proved that $U^0 = 0$, we get

$$U = \frac{U^*}{U_r} = \frac{U^*}{L_0} = \varepsilon U^1 + \varepsilon^2 U^2 + \dots$$

which is equivalent to :

$$\tilde{U} = \frac{U^*}{\varepsilon U_r} = \frac{U^*}{h_0} = U^1 + \varepsilon U^2 + \dots = \tilde{U}^0 + \varepsilon \tilde{U}^1 + \varepsilon^2 \tilde{U}^2 + \dots$$

Accordingly, for this low force level, the reference scale $U_r = L_0$ of the displacement is not properly chosen. We must consider $U_r = h_0$ for the leading term of the displacement to be different from zero. So the dimensionless equilibrium equations must be written again with $U_r = h_0$ as the new reference scale. The dimensionless displacement will still be noted with U . This new dimensional analysis does not modify the dimensionless equations (3.5) but only the components of F , E , Σ and H , where U must be changed into ϵU . In particular, the expression (3.3) of the tangent mapping F becomes:

$$(5.35) \quad F = \epsilon I_3 + \epsilon^2 \frac{\partial U}{\partial p_0} \kappa^{-1} + \epsilon \frac{\partial U}{\partial z} \overline{N_0}.$$

A new expansion of the displacement is then equivalent to change U^i into U^{i-1} for $i \geq 1$ in the previous results. In particular, expressions (5.34) become:

$$(5.36) \quad 2\Delta_t^0 = \frac{\hat{\partial}U^0}{\partial p_0} + \frac{\hat{\partial}U^0}{\partial p_0} = 0 \quad \text{and} \quad U^1 = \underline{U}^1 - z \frac{\partial U^0}{\partial p_0} N_0$$

where U^0 and \underline{U}^1 only depend on p_0 .

On the other hand, with this new reference scale of the displacement, the first non-zero terms of the expansion of F , E , Σ and \mathcal{H} can be calculated from (3.3), (3.4) and (5.35) as follows:

$$(5.37) \quad \begin{aligned} F^1 &= I_3, & F^2 &= \frac{\partial U^0}{\partial p_0} + \Theta^0 \overline{N_0}, \\ F^3 &= \frac{\partial U^2}{\partial z} \overline{N_0} + \frac{\partial \underline{U}^1}{\partial p_0} + z \left(\frac{\partial \Theta^0}{\partial p_0} + \frac{\partial U^0}{\partial p_0} C_0 \right), \\ 2E^3 &= F^3 + \overline{F^3} + \overline{F^2} F^2 & \text{and} & \quad \Sigma^4 = \mathcal{H}^5 = \beta \text{Tr}(E^4) I_3 + 2E^4 \end{aligned}$$

where $\Theta^0 = -\frac{\partial U^0}{\partial p_0} N_0$.

5.3.2. Asymptotic expansion of equations. For the low force level considered here, the displacement is of the thickness order and we have the following result:

RESULT 6.

For a shell non-inhibited in the nonlinear and in the linear range, subjected to a low force level $\mathcal{G} = \mathcal{F} = \epsilon^4$, the leading term U^0 of the new expansion of U depends only on p_0 and satisfies the conditions:

i) U^0 is a linearly inextensional mapping which verifies:

$$2\Delta_t^0 = \frac{\hat{\partial}U^0}{\partial_0} + \frac{\hat{\partial}U^0}{\partial_0} = 0 \quad \text{in} \quad \omega_0,$$

ii) U^0 is solution to the problem:

$$\begin{aligned} \operatorname{div}_{t3} (\chi + C_0 m_t^0 + \overline{\operatorname{div}(m_t^0) N_0}) &= -\bar{p} \quad \text{in } \omega_0, \\ U^0 = \Theta^0 = 0 &\quad \text{on } \gamma_0^1, \\ \chi \nu_0 + m_t^0 C_0 \nu_0 = m_t^0 \nu_0 = \operatorname{div}(m_t^0) \nu_0 = 0 &\quad \text{on } \gamma_0^2, \end{aligned}$$

where χ is a field of symmetrical tensor which depends on U^0, U^1 and U^2 , where N_0 denotes the normal to the initial configuration ω_0 , and where :

$$\begin{aligned} m_t^0 &= \frac{4\beta}{3(\beta + 2)} \operatorname{Tr}(K_t^0) I_0 + \frac{4}{3} K_t^0, \\ 2K_t^0 &= \frac{\hat{\partial}\Theta^0}{\partial p_0} + \frac{\hat{\partial}\overline{\Theta^0}}{\partial p_0} + \frac{\hat{\partial}U^0}{\partial p_0} C_0 + C_0 \frac{\hat{\partial}U^0}{\partial \theta}, \\ \Theta^0 &= -\frac{\overline{\partial U^0}}{\partial p_0} N_0, \quad p = \int_{-1}^1 f \, dz + g^+ + g^-. \end{aligned}$$

Before giving the proof of this result, let us notice that the expression of the field of symmetrical tensors χ , which is complex and depends on U^0, U^1 and U^2 , is not given explicitly. As in Result 3, it is not necessary because it will vanish in the associated weak formulation (see the next result).

P r o o f. The proof of this result is similar to the previous one. It can also be split into five steps.

i) Computation of \mathcal{H}^5

By using (5.37), problem \mathcal{P}^5 reduces to :

$$\frac{\partial \overline{N_0} \mathcal{H}^5}{\partial z} = 0 \quad \text{in } \Omega_0 \quad \text{and} \quad \overline{\mathcal{H}^5}^\pm N_0 = \pm g^\pm \quad \text{on } \Gamma_0^\pm$$

which implies that

$$(5.38) \quad \overline{N_0} \mathcal{H}^5 = 0 \quad \text{in } \Omega_0$$

Equivalently, according to (5.37) we get:

$$(5.39) \quad \overline{N_0} \Sigma^4 = \beta \operatorname{Tr}(E^4) \overline{N_0} + 2 \overline{N_0} E^4 = 0 \quad \text{in } \Omega_0$$

where E^4 is given by:

$$(5.40) \quad 2E^4 = F^3 + \overline{F^3} + \overline{F^2} F^2 = \frac{\partial U^2}{\partial z} \overline{N_0} + N_0 \frac{\partial \overline{U^2}}{\partial z} + 2(\Delta^1 + z K^0)$$

with

$$\begin{aligned}
 2\Delta^1 &= \frac{\overline{\partial U^1}}{\partial p_0} + \frac{\partial \underline{U}^1}{\partial p_0} + \frac{\overline{\partial U^0}}{\partial p_0} \frac{\partial U^0}{\partial p_0} + \frac{\overline{\partial U^0}}{\partial p_0} \Theta^0 \overline{N_0} \\
 &\quad + N_0 \overline{\Theta^0} \frac{\partial U^0}{\partial p_0} + \|\Theta^0\|^2 N_0 \overline{N_0}, \\
 2K^0 &= \frac{\partial \Theta^0}{\partial p_0} + \frac{\overline{\partial \Theta^0}}{\partial p_0} + \frac{\partial U^0}{\partial p_0} C_0 + C_0 \frac{\overline{\partial U^0}}{\partial p_0}.
 \end{aligned}
 \tag{5.41}$$

Thus equation (5.39) enables us to calculate $\partial U^2/\partial z$. Indeed we get:

$$\begin{aligned}
 \frac{\partial U^2}{\partial z} &= -\frac{1}{\beta + 2} \left[\beta \text{Tr}(\Delta^1 + zK^0) \right. \\
 &\quad \left. + 2\overline{N_0}(\Delta^1 + zK^0)N_0 \right] N_0 - 2\Pi_0(\Delta^1 + zK^0)N_0.
 \end{aligned}
 \tag{5.42}$$

Replacing the expression (5.42) of $\partial U^2/\partial z$ in (5.40), and decomposing Δ^1 and K^0 into $T\omega_0 \oplus \mathbb{R}N_0$, we obtain :

$$E^4 = -\frac{\beta}{\beta + 2} \text{Tr}(\Delta_t^1 + zK_t^0)N_0\overline{N_0} + (\Delta_t^1 + zK_t^0)
 \tag{5.43}$$

with :

$$\begin{aligned}
 2\Delta_t^1 &= 2\Pi_0\Delta^1\Pi_0 = \frac{\hat{\partial U}^1}{\partial p_0} + \frac{\hat{\partial U}^1}{\partial p_0} + \frac{\overline{\partial U^0}}{\partial p_0} \frac{\partial U^0}{\partial p_0}, \\
 2K_t^0 &= 2\Pi_0K^0\Pi_0 = \frac{\hat{\partial \Theta}^0}{\partial p_0} + \frac{\overline{\hat{\partial \Theta}^0}}{\partial p_0} + \frac{\hat{\partial U}^0}{\partial p_0} C_0 + C_0 \frac{\overline{\hat{\partial U}^0}}{\partial p_0}.
 \end{aligned}
 \tag{5.44}$$

Hence the expression of \mathcal{H}^5 becomes:

$$\mathcal{H}^5 = \Sigma^4 = \frac{1}{2}(n_t^1 + 3zm_t^0)
 \tag{5.45}$$

where:

$$\begin{aligned}
 n_t^1 &= \frac{4\beta}{\beta + 2} \text{Tr}(\Delta_t^1)I_0 + 4(\Delta_t^1), \\
 m_t^0 &= \frac{4\beta}{3(\beta + 2)} \text{Tr}(K_t^0)I_0 + \frac{4}{3}(K_t^0).
 \end{aligned}
 \tag{5.46}$$

ii) Characterization of \underline{U}^1

Using (5.37), problem \mathcal{P}^6 can be reduced to :

$$(5.47) \quad \begin{aligned} \operatorname{div}_{t3}(\Pi_0 \mathcal{H}^5) + \frac{\partial \overline{N_0} \mathcal{H}^6}{\partial z} &= 0 \quad \text{in } \Omega_0, \\ \overline{\mathcal{H}^6}^\pm N_0 &= 0 \quad \text{on } \Gamma_0^\pm. \end{aligned}$$

Then, according to (5.45), an integration upon the thickness leads to

$$(5.48) \quad \operatorname{div}_{t3}(m_t^1) = 0 \quad \text{in } \omega_0$$

whose solutions verify

$$(5.49) \quad 2\Delta_t^1 = \frac{\hat{\partial} U^1}{\partial p_0} + \frac{\overline{\hat{\partial} U^1}}{\partial p_0} + \frac{\overline{\partial U^0}}{\partial p_0} \frac{\partial U^0}{\partial p_0} = 0.$$

Finally, taking into account (5.49), expression (5.45) reduces to:

$$(5.50) \quad \mathcal{H}^5 = \Sigma^4 = \frac{3}{2} z m_t^0.$$

iii) Expression of \mathcal{H}^6

Now let us integrate the Eq. (5.47) of problem \mathcal{P}^6 with respect to z . We get:

$$(5.51) \quad \overline{N_0} \mathcal{H}^6 = \frac{3(1-z^2)}{4} \operatorname{div}_{t3}(m_t^0).$$

Thus \mathcal{H}^6 can be written as :

$$(5.52) \quad \mathcal{H}^6 = \Pi_0 \mathcal{H}^6 + N_0 \overline{N_0} \mathcal{H}^6 = \Pi_0 \mathcal{H}^6 + \frac{3(1-z^2)}{4} N_0 \operatorname{div}_{t3}(m_t^0).$$

On the other hand, according to (5.37), we have:

$$(5.53) \quad \mathcal{H}^6 = \Sigma^5 + \Sigma^4 \overline{F^2}.$$

Hence (5.52) can be written as :

$$(5.54) \quad \begin{aligned} \mathcal{H}^6 &= \Pi_0 \Sigma^5 + \Pi_0 \Sigma^4 \overline{F^2} + \frac{3(1-z^2)}{4} N_0 \operatorname{div}_{t3}(m_t^0) \\ &= \Pi_0 \Sigma^5 \Pi_0 + \Pi_0 \Sigma^5 N_0 \overline{N_0} + \frac{3}{2} z m_t^0 \frac{\overline{\partial U^0}}{\partial p_0} + \frac{3(1-z^2)}{4} N_0 \operatorname{div}_{t3}(m_t^0), \end{aligned}$$

where F^2 and Σ^4 have been replaced by their expressions (5.37) and (5.50).

On the other hand, multiplying (5.53) by $\overline{N_0}$ and using (5.39), we get:

$$\Sigma^5 N_0 = \frac{3(1 - z^2)}{4} \overline{\text{div}_{t3}(m_t^0)}$$

because Σ^5 is symmetrical.

Eventually, the expression (5.54) of \mathcal{H}^6 becomes:

$$(5.55) \quad \mathcal{H}^6 = \Pi_0 \Sigma^5 \Pi_0 + \frac{3}{2} z m_t^0 \frac{\partial U^0}{\partial p_0} + \frac{3(1 - z^2)}{4} (\Pi_0 \overline{\text{div}_{t3}(m_t^0)} \overline{N_0} + N_0 \text{div}_{t3}(m_t^0)).$$

iv) Equilibrium equations

The cancellation of the factor of ε^7 in the expansion of Eq. (3.5) leads to problem \mathcal{P}^7 :

$$(5.56) \quad \begin{aligned} \text{div}_{t3}(\Pi_0 \mathcal{H}^6 + z C_0 \mathcal{H}^5) - \text{Tr}(C_0) \overline{N_0} \mathcal{H}^6 - z \text{div}(C_0) \Pi_0 \mathcal{H}^5 + \frac{\partial \overline{N_0} \mathcal{H}^7}{\partial z} \\ = -\overline{f} \quad \text{in } \Omega_0, \\ \overline{\mathcal{H}^7}^\pm N_0 = \pm g^\pm \quad \text{in } \Gamma_0^\pm. \end{aligned}$$

By using (5.50) and (5.55), an integration upon the thickness leads to:

$$(5.57) \quad \begin{aligned} \text{div}_{t3} \left(\int_{-1}^1 \Pi_0 \Sigma^5 \Pi_0 dz + C_0 m_t^0 + \Pi_0 \overline{\text{div}_{t3}(m_t^0)} \overline{N_0} \right) \\ - \text{Tr}(C_0) \text{div}_{t3}(m_t^0) - \text{div}(C_0) m_t^0 = -\overline{p} \quad \text{in } \omega_0 \end{aligned}$$

where $p = \int_{-1}^1 f dz + g^+ + g^-$.

Finally, using the following properties of the divergence div_{t3} :

$$\text{div}_{t3}(m_t^0) \Pi_0 = \text{div}(m_t^0)$$

and

$$\text{Tr}(C_0) \text{div}_{t3}(m_t^0) + \text{div}(C_0) m_t^0 = \text{div}_{t3}(\text{Tr}(C_0) m_t^0)$$

we transform the last equation into:

$$(5.58) \quad \operatorname{div}_{t3} (\chi + C_0 m_t^0 + \overline{\operatorname{div}}(m_t^0) \overline{N_0}) = -\bar{p} \quad \text{in } \omega_0$$

which constitutes the equilibrium equation of Result 6 with:

$$(5.59) \quad \chi = \int_{-1}^1 \Pi_0 \Sigma^5 \Pi_0 dz - \operatorname{Tr}(C_0) m_t^0.$$

We recall that χ is a field of symmetrical tensors.

v) Boundary conditions

To conclude the proof, let us examine the boundary conditions. The clamped condition $U = 0$ on Γ_0 easily leads to :

$$(5.60) \quad U^0 = \Theta^0 = 0 \quad \text{on } \gamma_0^1.$$

The boundary conditions on γ_0^2 can be obtained from the expansion of the condition $\overline{\mathcal{H}} \kappa_0^{-1} \nu_0 = 0$. Taking into account expressions (5.50) and (5.55) of \mathcal{H}^5 and \mathcal{H}^6 , we get:

$$(5.61) \quad \Pi_0 \Sigma^5 \Pi_0 \nu_0 + \frac{3(1-z^2)}{4} N_0 \operatorname{div}_{t3}(m_t^0) \nu_0 \\ + \frac{3z}{2} \frac{\partial U^0}{\partial p_0} m_t^0 \nu_0 + \frac{3z^2}{2} m_t^0 C_0 \nu_0 = 0 \quad \text{on } \Gamma_0^2.$$

The first equation of (5.61) directly leads to

$$(5.62) \quad m_t^0 \nu_0 = 0 \quad \text{on } \gamma_0^2.$$

Let us project the second equation onto $T\omega_0$ and the normal N_0 , and integrate the two equations obtained upon the thickness. Taking into account (5.62), we obtain

$$(5.63) \quad \int_{-1}^1 \Pi_0 \Sigma^5 \Pi_0 dz \nu_0 + m_t^0 C_0 \nu_0 = 0 \quad \text{and} \quad \operatorname{div}(m_t^0) \nu_0 = 0 \quad \text{on } \gamma_0^2,$$

where we have used the property $\operatorname{div}_{t3}(m_t^0) \nu_0 = \operatorname{div}_{t3}(m_t^0) \Pi_0 \nu_0 = \operatorname{div}(m_t^0) \nu_0$.

Finally, taking into account (5.62), the first equation of (5.63) is equivalent to:

$$\chi\nu_0 + m_t^0 C_0 \nu_0 = 0 \quad \text{on } \gamma_0^2$$

where χ is given by (5.59). This concludes the proof of Result 6. □

REMARK 1.

Let us notice that if we decompose U^0 on $T\omega_0 \oplus \mathbb{R}N_0$ as follows:

$$U^0 = V^0 + u^0 N_0,$$

then Δ_t^0 and K_t^0 can be written as:

$$\Delta_t^0 = \frac{1}{2} \left(\frac{\hat{\partial} \overline{V^0}}{\partial p_0} + \frac{\hat{\partial} V^0}{\partial p_0} \right) - u^0 C_0$$

and

$$K_t^0 = \frac{1}{2} \left(\frac{\hat{\partial} \Theta^0}{\partial p_0} + \frac{\overline{\hat{\partial} \Theta^0}}{\partial p_0} + \frac{\hat{\partial} V^0}{\partial p_0} C_0 + C_0 \frac{\overline{\hat{\partial} V^0}}{\partial p_0} - u^0 C_0^2 \right)$$

with $\Theta^0 = -\frac{\overline{\partial u^0}}{\partial p_0} - C_0 V^0$. We then recognize the classical expressions of the linear membrane strain Δ_t^0 and of the linear curvature change K_t^0 .

5.3.3. The linear pure bending model. Let us define the space of linear inextensional displacements :

$$(5.64) \quad V_{\text{inex}}(\omega_0) = \left\{ U : \omega_0 \rightarrow \mathbb{R}^3 \text{ "smooth", } \frac{\hat{\partial} U}{\partial p_0} + \frac{\overline{\hat{\partial} U}}{\partial p_0} = 0 \text{ in } \omega_0 \right. \\ \left. \text{and } U = \frac{\overline{\partial U}}{\partial p_0} N_0 = 0 \text{ on } \gamma_0^1 \right\}.$$

Then equations of Result 6 can be written in the following weak formulation:

RESULT 7.

For a shell non-inhibited in the nonlinear and in the linear range, subjected to a low force level $\mathcal{F} = \mathcal{G} = \varepsilon^4$, the leading term U^0 of the expansion of the displacement is a solution of the linear pure bending model:

$$(5.65) \quad U^0 \in V_{\text{inex}}(\omega_0), \\ \int_{\omega_0} \text{Tr}(m_t^0 \delta K_t^0) d\omega_0 = \int_{\omega_0} \overline{p} \delta U^0 d\omega_0 \quad \forall \delta U^0 \in V_{\text{inex}}(\omega_0),$$

where

$$2K_t^0 = \frac{\hat{\partial}\Theta^0}{\partial p_0} + \frac{\overline{\hat{\partial}\Theta^0}}{\partial p_0} + \frac{\hat{\partial}U^0}{\partial p_0} C_0 + C_0 \frac{\overline{\hat{\partial}U^0}}{\partial p_0}, \quad \Theta^0 = -\frac{\overline{\partial U^0}}{\partial p_0} N_0,$$

$$m_t^0 = \frac{4\beta}{3(\beta+2)} \text{Tr}(K_t^0) I_0 + \frac{4}{3} K_t^0 \quad \text{and} \quad p = \int_{-1}^1 f dz + g^+ + g^-.$$

The proof of this result is similar to the one of Result 4. It is based on the successive use of the Stokes formula. We just need the restriction $\delta U^0 \in V_{\text{inex}}(\omega_0)$ to eliminate χ in the weak formulation of the Result 6. □

Thus we have justified the linear pure bending model for a non-inhibited shell in the nonlinear and in the linear range, subjected to a low force level of ε^4 order. For this force level, the displacements are of the thickness order ($U_r = h_0$). This linear pure bending model has been also justified by asymptotic expansion of the three-dimensional equations of linear elasticity in [14][15][21]. But contrary to these works, the linear pure bending model is deduced here from the nonlinear three-dimensional elasticity.

5.4. Domain of validity of the linear pure bending model

It is possible to prove that for a non-inhibited shell in the nonlinear and in the linear range, the linear pure bending model is valid for force levels lower than ε^4 . Indeed, for a force level $\mathcal{F} = \mathcal{G} = \varepsilon^5$, we would obtain the weak formulation (5.65) without a right side whose solutions satisfy $K_t^0 = 0$. As U^0 is an inextensional displacement in the linear range, the linear version of the rigid motion lemma implies that $U^0 = 0$. Following the same reasoning as in the previous sections, we find out that the reference scale of the displacement is not properly chosen. We have to consider $U_r = \varepsilon h_0$. Then, a new dimensional analysis and a new asymptotic expansion of equations lead again to the linear pure bending model. For the low force level considered here, the problem becomes linear with respect to the displacement. In fact, with a recurrence on n , we can prove the following result:

RESULT 8.

For a non-inhibited shell, in the linear and the nonlinear range, subjected to low force levels of $\varepsilon^{n \geq 4}$ order, the order of magnitude of the displacement is $U_r = \varepsilon^{n-4} h_0$. Moreover, the leading term U^0 of the expansion of the displacement satisfies equations of the pure bending model of Result 7.

5.5. The linear membrane model for linearly inhibited shells

We see that for a non-inhibited shell in the nonlinear range subjected to low force levels of ε^4 order and lower, we have to distinguish the linearly non-inhibited from the linearly inhibited shells. In Subsecs. 5.3 and 5.4, we proved that for a linearly non-inhibited shell, we obtain the linear pure bending model. For a linearly inhibited shell, the following result is obtained:

RESULT 9.

For a non-inhibited shell in the nonlinear range but inhibited in the linear range, and subjected to low force levels $\mathcal{F} = \mathcal{G} = \varepsilon^{n \geq 4}$, the magnitude of the displacement is $U_r = \varepsilon^{n-2} h_0$. Moreover, the leading term U^0 of the expansion of the displacement is a solution of the following linear membrane model:

$$\begin{aligned} \operatorname{div}(n_t^0) &= -\bar{p}_t \quad \text{in } \omega_0, & \operatorname{Tr}(n_t^0 C_0) &= -p_n \quad \text{in } \omega_0, \\ U^0 &= 0 \quad \text{on } \gamma_0^1, & n_t^0 \nu_0 &= 0 \quad \text{on } \gamma_0^2, \end{aligned}$$

where

$$n_t^0 = \frac{4\beta}{2+\beta} \operatorname{Tr}(\Delta_t^0) I_0 + 4\Delta_t^0, \quad 2\Delta_t^0 = \frac{\hat{\partial}V^0}{\partial p_0} + \frac{\hat{\partial}V^0}{\partial p_0} - 2u^0 C_0,$$

$$p_t = g_t^+ + g_t^- + \int_{-1}^1 f_t dz \quad \text{and} \quad p_n = g_n^+ + g_n^- + \int_{-1}^1 f_n dz.$$

For the proof of this result, we refer the reader to the next section where the study is similar.

6. Inhibited shells in the nonlinear range

It must be reminded that for a shell subjected to a severe force level of ε order, the asymptotic expansion of equations leads to the nonlinear membrane model whatever the nonlinear rigidity of the middle surface is (see Sec. 4). For a high force level of ε^2 order we had to distinguish the nonlinear inhibited from the nonlinear non-inhibited shells. In the last section we have completed the classification for non-inhibited shells, in the nonlinear range.

In this section, we will study the other branch of the classification which corresponds to inhibited shells in the nonlinear range. In order to do this, we resume the calculations after the nonlinear membrane model obtained at the Result 1.

6.1. The linear membrane model for a high force level

We consider a inhibited shell in the nonlinear range subjected to a high force level $\mathcal{G} = \mathcal{F} = \varepsilon^2$. We first prove that for this force level, the order of magnitude of the displacement is $U_r = h_0$ and not L_0 . Then, a new dimensional analysis will lead to the linear membrane model.

6.1.1. New reference scale of the displacement. For a force level of ε^2 order, we obtain the weak formulation (4.3) of the Result 2 without a right-hand side, whose solutions are the inextensional mappings ϕ^0 which satisfy

$$(6.1) \quad \frac{\partial \phi^0}{\partial p_0} \frac{\partial \phi^0}{\partial p_0} = I_0 \quad \text{in } \omega_0.$$

As the shell is assumed to be inhibited in the nonlinear range, the space of inextensional mappings reduces to identity. Hence we have $\phi^0 = i_{\omega_0}$ or equivalently $U^0 = 0$. The expression of N introduced in (4.1) becomes $N = N_0$ and we still have:

$$(6.2) \quad U^1 = U^1(p_0) \quad \text{in } \omega_0.$$

Therefore, for this force level, we have to consider $U_r = h_0$ so as U^0 to be different from zero. So we make a new dimensional analysis of Eq. (2.4) with $U_r = h_0$ as the new reference scale, and we still denote $U = U^*/h_0$ the new dimensionless displacement. As in Sec. 5.3, this new dimensional analysis does not modify the dimensionless Equation (3.5) but only the components of F , E , Σ and H , where U must be changed into εU . The expression of the tangent mapping F that we now have to consider is given by (5.35):

$$(6.3) \quad F = \varepsilon I_3 + \varepsilon^2 \frac{\partial U}{\partial p_0} \kappa^{-1} + \varepsilon \frac{\partial U}{\partial z} \overline{N}_0.$$

A new expansion of the displacement is then equivalent to change U^i into U^{i-1} for $i \geq 1$ in the previous results. In particular (6.2) gives us

$$(6.4) \quad U^0 = U^0(p_0).$$

On the other hand, with this new reference scale for the displacement, we must calculate again the first non-zero terms of the expansions of F , E , Σ and \mathcal{H} . According to (3.3), (3.4) and (6.3), we have $F^1 = I_3$ and:

$$(6.5) \quad \begin{aligned} F^2 &= \frac{\partial U^1}{\partial z} \overline{N}_0 + \frac{\partial U^0}{\partial p_0}, & 2E &= \overline{F^2} + F^2, \\ \Sigma^3 &= \beta \text{Tr}(E^3) I_3 + 2E^3, & \mathcal{H}^4 &= \Sigma^3. \end{aligned}$$

6.1.2. Asymptotic expansion. The asymptotic expansion of the new dimensionless equations leads to the following result:

RESULT 10.

For a shell inhibited in the non-linear range and subjected to a high force level $\mathcal{G} = \mathcal{F} = \varepsilon^2$, the leading term $U^0 = (V^0, u^0)$ of the expansion of $U = (V, u)$ only depends on p_0 and satisfies the linear membrane model :

$$\begin{aligned} \operatorname{div}(n_t^0) &= -\bar{p}_t \quad \text{in } \omega_0, & \operatorname{Tr}(n_t^0 C_0) &= -p_n \quad \text{in } \omega_0, \\ U^0 &= 0 \quad \text{on } \gamma_0^1, & n_t^0 \nu_0 &= 0 \quad \text{on } \gamma_0^2. \end{aligned}$$

where the expressions of n_t^0 , Δ_t^0 , p_t and p_n are those of Result 9.

P r o o f. The proof is split into two steps.

i) *Determination of U^1*

The cancellation of the factor of ε^4 in the new expansion of the dimensionless equilibrium Eq. (3.5) leads to the new problem \mathcal{P}^4 :

$$\begin{aligned} \frac{\partial \bar{\mathcal{H}}^4 N_0}{\partial z} &= 0 \quad \text{in } \omega_0, \\ \left[\bar{\mathcal{H}}^4 N_0 \right]^\pm &= 0 \quad \text{on } \Gamma_0^\pm, \end{aligned}$$

which implies that $\bar{\mathcal{H}}^4 N_0 = 0$ or equivalently that:

$$(6.6) \quad \beta \operatorname{Tr}(E^3) N_0 + 2E^3 N_0 = 0 \quad \text{in } \omega_0$$

in view of (6.5). On the other hand, we have:

$$2E^3 = F^2 + \bar{F}^2 = \frac{\partial U^1}{\partial z} \bar{N}_0 + N_0 \frac{\partial \bar{U}^1}{\partial z} + \frac{\partial U^0}{\partial p_0} + \frac{\partial \bar{U}^0}{\partial p_0}.$$

Now if we decompose $\frac{\partial U^0}{\partial p_0}$ as follows:

$$\frac{\partial U^0}{\partial p_0} = \Pi \frac{\partial U^0}{\partial p_0} + N_0 \bar{N}_0 \frac{\partial U^0}{\partial p_0}$$

we get:

$$\operatorname{Tr}(E^3) = \bar{N}_0 \frac{\partial U^1}{\partial z} + \operatorname{Tr}(\Delta_t^0) \quad \text{and} \quad 2E^3 N_0 = \frac{\partial U^1}{\partial z} + \left(\bar{N}_0 \frac{\partial U^1}{\partial z} \right) N_0 + \frac{\partial \bar{U}^0}{\partial p_0} U^0 N_0,$$

with $2\Delta_t^0 = \Pi_0 \frac{\partial \overline{U^0}}{\partial p_0} + \Pi_0 \frac{\partial U^0}{\partial p_0}$. According to the Remark 1, Δ_t^0 corresponds to the classical linear membrane strain.

Thus (6.6) can be written as:

$$\beta \left(\overline{N_0} \frac{\partial U^1}{\partial z} + \text{Tr}(\Delta_t^0) \right) N_0 + \frac{\partial U^1}{\partial z} + \left(\overline{N_0} \frac{\partial U^1}{\partial z} \right) N_0 + \frac{\partial \overline{U^0}}{\partial p_0} N_0 = 0$$

and the projection of this equation onto $T\omega_0$ and N_0 gives us:

$$\Pi_0 \frac{\partial U^1}{\partial z} = -\frac{\partial \overline{U^0}}{\partial p_0} N_0 \quad \text{and} \quad \overline{N_0} \frac{\partial U^1}{\partial z} = -\frac{\beta}{\beta+2} \text{Tr}(\Delta_t^0)$$

which leads to:

$$\frac{\partial U^1}{\partial z} = -\frac{\partial \overline{U^0}}{\partial p_0} N_0 - \frac{\beta}{\beta+2} \text{Tr}(\Delta_t^0) N_0.$$

As U^0 depends only on p_0 according to (6.4), we get finally:

$$(6.7) \quad U^1 = \underline{U}^1 - z \left(\frac{\partial \overline{U^0}}{\partial p_0} N_0 + \frac{\beta}{\beta+2} \text{Tr}(\Delta_t^0) N_0 \right)$$

where \underline{U}^1 only depends on p_0 .

The expressions of E^3 , Σ^3 and H^4 can also be calculated from (6.5). We get:

$$(6.8) \quad E^3 = \Delta_t^0 - \frac{\beta}{\beta+2} \text{Tr}(\Delta_t^0) N_0 \overline{N_0} \quad \text{and} \quad \Sigma^3 = \mathcal{H}^4 = \frac{1}{2} n_t^0$$

where $n_t^0 = \frac{4\beta}{\beta+2} \text{Tr}(\Delta_t^0) I_0 + 4\Delta_t^0$.

ii) Linear membrane equations

Problem \mathcal{P}^5 then reduces to:

$$\begin{aligned} \text{div}_{t3}(\Pi_0 \mathcal{H}^4) + \frac{\partial \overline{\mathcal{H}^5} N_0}{\partial z} &= -\bar{f} \quad \text{in } \Omega_0, \\ \left[\overline{\mathcal{H}^5} N_0 \right]^\pm &= \pm g^\pm \quad \text{on } \Gamma_0^\pm. \end{aligned}$$

Using (6.8), an integration upon the thickness of the above equations leads to:

$$(6.9) \quad \text{div}_{t3}(n_t^0) = -\bar{p} \quad \text{in } \omega_0$$

where $p = g^+ + g^- + \int_{-1}^{+1} f dz$. As n_t^0 is a field of endomorphisms on $T\omega_0$, we can decompose easily $\text{div}_{t3}(n_t^0)$ into $T\omega_0 \oplus \mathbb{R}N_0$. The last equation then becomes:

$$\text{div}(n_t^0) + \text{Tr}(n_t^0 C_0) \overline{N_0} = -p \quad \text{on } \omega_0$$

which leads to the two classical equations of the membrane model of Result 10:

$$\text{div}(n_t^0) = -\overline{p}_t \quad \text{and} \quad \text{Tr}(n_t^0 C_0) = -p_n \quad \text{in } \omega_0.$$

Finally, the boundary conditions on γ_0^1 and γ_0^2 can be obtained easily from the expansion of the three-dimensional boundary conditions on Γ_0^1 and Γ_0^2 . This concludes the proof of Result 10. □

6.1.3. Weak formulation. Let us define the following space of admissible displacements :

$$V(\omega_0) = \{U : \omega_0 \rightarrow \mathbb{R}^3, \text{ "smooth", } U = 0 \text{ on } \gamma_0^1\}$$

Then the linear membrane equations can be written in the following weak formulation :

RESULT 11.

The displacement $U^0 \in V(\omega_0)$ satisfies:

$$(6.10) \quad \int_{\omega_0} \text{Tr}(n_t^0 \delta \Delta_t^0) d\omega_0 = \int_{\omega_0} \overline{p} \delta U^0, \quad \forall \delta U^0 \in V(\omega_0)$$

where $p = p_t + p_n N_0$.

This weak formulation is identical to the one obtained by asymptotic expansion from the linear three-dimensional elasticity, with an intrinsic approach [4][5][7] or with a description of the shell in local coordinates [14]. But contrary to these other justifications, the linear membrane model is deduced here from the nonlinear equilibrium three-dimensional equations without any assumption on the scalings concerning the displacements.

6.2. The linear membrane model still valid for linearly inhibited shells

For moderate and lower force levels, we have now to distinguish the linearly inhibited from the linearly non-inhibited shells. For linearly inhibited shells we have the following result:

RESULT 12.

For a shell inhibited in the linear and the nonlinear range, the linear membrane model is still valid for force levels of $\varepsilon^{n \geq 3}$ order. For these force levels, the order of magnitude of the displacement is $U_r = h_0 \varepsilon^{n-2}$.

The proof can be obtained with a recurrence on n . The main step is to solve the weak formulation (6.10) without a right side. Considering the associated minimization problem, we obtain that U^0 is an inextensional displacement in the linear range. As the shell is linearly inhibited, we have $U^0 = 0$. Following the proof of Result 10, a new dimensional analysis with $U_r = \varepsilon h_0$ and a new asymptotic expansion of equations lead again to the linear membrane model, with or without a right side, according to the considered force level. This operation can be repeated until we find $U^0 \neq 0$. Finally, using a recurrence on n , we find that for force levels of $\varepsilon^{n \geq 3}$ order, the order of magnitude of the displacement is $U_r = h_0 \varepsilon^{n-2}$, and the asymptotic model obtained is the linear membrane one. \square

6.3. Domain of validity of the linear membrane model

We proved in Result 10 that the linear membrane model is valid for an inhibited shell in the non-linear range, subjected to a high force level of ε^2 order. For moderate and lower force levels of $\varepsilon^{n \geq 3}$, this model is still valid if the shell is inhibited in the linear range as well.

We recall that in the Subsec. 5.5, we have proved that this linear membrane model is also obtained for a non-inhibited shell in the nonlinear range but linearly inhibited, subjected to low force levels of $\varepsilon^{n \geq 4}$ order. Thus, the linear membrane model is valid for a linearly inhibited shell subjected to low force levels of $\varepsilon^{n \geq 4}$ order, whatever the nonlinear geometric rigidity is.

6.4. Two other models for linearly non-inhibited shells

We study now the last case: a shell subjected to moderate and low force levels, linearly non-inhibited, but always inhibited in the nonlinear range. The asymptotic expansion of the three-dimensional equilibrium Equation (3.5) leads to calculations similar to the ones of the previous sections. Thus we only give here the asymptotic models which are obtained.

6.4.1. Another coupling model for a moderate force level. For a moderate force level $\mathcal{F} = \mathcal{G} = \varepsilon^3$, the order of magnitude of the displacement is $U_r = h_0$ and the two first terms U^0 and U^1 of the expansion of the displacement are solution of a variational problem which couples membrane and bending effects.

Let us recall the definition of the following admissible spaces of displacements:

$$V(\omega_0) = \{U : \omega_0 \rightarrow \mathbb{R}^3, \text{ "smooth", } U = 0 \text{ on } \gamma_0^1\},$$

$$V_{\text{inex}}(\omega_0) = \left\{ U \in V(\omega_0), \frac{\hat{\partial}U}{\partial p_0} + \overline{\frac{\hat{\partial}U}{\partial p_0}} = 0 \text{ in } \omega_0 \text{ and } \overline{\frac{\partial U}{\partial p_0}} N_0 = 0 \text{ on } \gamma_0^1 \right\}.$$

Then we have the following result :

RESULT 13.

For a shell inhibited in the nonlinear range but linearly non-inhibited, subjected to a moderate force level $\mathcal{F} = \mathcal{G} = \varepsilon^3$, $(U^0, U^1) \in V_{\text{inex}}(\omega_0) \times V(\omega_0)$ and satisfies the following weak problem:

$$\int_{\omega_0} \text{Tr} (n_t^1 \delta \Delta_t^1 + m_t^0 \delta K_t^0) d\omega_0 = \int_{\omega_0} (\bar{p} \delta U^1 - \text{Tr}(C_0) \overline{M} \delta U^0 + \overline{M} \delta \Theta^0) d\omega_0$$

$$\forall (\delta U^0, \delta U^1) \in V_{\text{inex}}(\omega_0) \times V(\omega_0)$$

with:

$$n_t^1 = \frac{4\beta}{2 + \beta} \text{Tr}(\Delta_t^1) I_0 + 4\Delta_t^1,$$

$$2\Delta_t^1 = \frac{\hat{\partial}U^1}{\partial p_0} + \frac{\hat{\partial}U^1}{\partial_0} + \frac{\overline{\partial U^0}}{\partial p_0} \frac{\partial U^0}{\partial p_0},$$

$$m_t^0 = \frac{4\beta}{3(\beta + 2)} \text{Tr}(K_t^0) I_0 + \frac{4}{3} K_t^0,$$

$$K_t^0 = \frac{\hat{\partial}\Theta^0}{\partial p_0} + \frac{\hat{\partial}\Theta^0}{\partial p_0} + \frac{\hat{\partial}U^0}{\partial p_0} C_0 + C_0 \frac{\hat{\partial}U^0}{\partial p_0},$$

$$p = g^+ + g^- + \int_{-1}^1 f dz,$$

$$M = g^+ - g^- + \int_{-1}^1 z f dz.$$

For the proof of this result, which is similar to the one of Result 4, we refer the reader to Sec. 5.1.

□

This coupling model is similar to the one obtained in Result 4, with different expressions of the strain measures K_t^0 and Δ_t^1 . Here K_t^0 is the linear classical variation of curvature. The coupling between U^0 and U^1 is contained in the non-classical membrane strain Δ_t^1 , which is linear with respect to U^1 but nonlinear with respect to U^0 .

The physical interpretation of this model is also similar to the one of Result 4. The solution of this model is the displacement $U^0 + \varepsilon U^1$, where U^0 is a linear inextensional displacement which generates the curvature variation K_t^0 , and εU^1 a small displacement which generates with U^0 the nonlinear membrane strain Δ_t^1 .

6.4.2. The linear pure bending model for low force levels. Let us consider to finish a shell subjected to low force levels $\mathcal{F} = \mathcal{G}_g = \varepsilon^{n \geq 4}$. Then we have the following result:

RESULT 14.

For a shell inhibited in the nonlinear range but linearly non-inhibited, and subjected to low force levels $\mathcal{F} = \mathcal{G} = \varepsilon^{n \geq 4}$, the order of magnitude of the displacement is $U_r = h_0 \varepsilon^{n-4}$. Moreover the leading term U^0 of the expansion of the displacement is a solution of the linear pure bending model of Result 7.

For the proof of this result, we refer the reader to Sec. 5.3 where the calculations are similar. □

Thus, according to Result 8, the linear pure bending model is valid for a linearly non-inhibited shell subjected to low force levels of $\varepsilon^{n \geq 4}$ order, whatever the non-linear geometric rigidity is. We find again the classical results obtained in [14][21][22] from linear elasticity.

7. Conclusion

In the second part of this paper we have established a classification of asymptotic models for strongly curved shells. The results are different from those obtained in the first part for shallow shells [10]. In particular, for the same force level, the obtained behaviour depend on the geometric rigidity of the middle surface of the shell, in the linear and in the nonlinear range.

As in the first part, we have studied only one combination of $(\mathcal{F}_t, \mathcal{F}_n, \mathcal{G}_t, \mathcal{G}_n)$ for each value of $\tau = \text{Max}(\mathcal{F}_t, \mathcal{F}_n, \mathcal{G}_t, \mathcal{G}_n)$. However, the study of the other combinations is not fundamental; it would lead to the same two-dimensional models with a right side slightly different. The following table resumes the so obtained classification with respect to τ , where the abbreviation *L.I.S.* (respectively *N.L.I.S.*) means *linearly inhibited shell* (respectively *nonlinearly inhibited shell*): with:

$$n_t^0 = \frac{4\beta}{\beta+2} \text{Tr}(\Delta_t^0) I_0 + 4\Delta_t^0, \quad n_t^1 = \frac{4\beta}{\beta+2} \text{Tr}(\Delta_t^1) I_0 + 4\Delta_t^1,$$

$$m_t^0 = \frac{4\beta}{3(\beta+2)} \text{Tr}(K_t^0) I_0 + \frac{4}{3} K_t^0, \quad \Theta^0 = -\frac{\partial U^0}{\partial p_0} N_0,$$

$$p = \int_{\omega_0} f dz + g^+ + g^-, \quad M = \int_{\omega_0} z f dz + g^+ - g^-.$$

Table 1. Non-inhibited shells in the nonlinear range.

\mathcal{T}	U_r	Shell model	Δ_t^0, K_t^0
ε	L_0	<p>nonlinear membrane model</p> <p>$\phi^0 \in Q(\omega_0)$ and $\forall \delta\phi^0 \in V(\omega_0)$</p> $\int_{\omega_0} \text{Tr}(n_t^0 \delta\Delta_t^0) d\omega_0 = \int_{\omega_0} \bar{p} \delta\phi^0 d\omega_0$	$2\Delta_t^0 = \frac{\partial \bar{\phi}^0}{\partial p_0} \frac{\partial \phi^0}{\partial p_0} - I_0$
ε^2	L_0	<p>nonlinear coupling model</p> <p>$(\phi^0, U^1) \in Q_{\text{inex}}(\omega_0) \times V(\omega_0)$</p> $\int_{\omega_0} \text{Tr}(n_t^1 \delta\Delta_t^1 + m_t^0 \delta K_t^0) d\omega^0 =$ $\int_{\omega_0} (\bar{p} \delta U^1 - \text{Tr}(C_0) \bar{M} \delta \phi^0 + \bar{M} \delta N) d\omega_0$ <p>$\forall (\delta\phi^0, \delta U^1) \in V_{\text{inex}}^{\phi^0}(\omega_0) \times V(\omega_0)$</p>	$2\Delta_t^1 = \frac{\partial \bar{\phi}^0}{\partial p_0} \frac{\partial U^1}{\partial p_0} + \frac{\partial \bar{U}^1}{\partial p_0} \frac{\partial \phi^0}{\partial p_0}$ $K_t^0 = \bar{C} - C_0$ <p>ϕ^0 is inextensional</p>
ε^3	L_0	<p>nonlinear pure bending model</p> <p>$\phi^0 \in Q_{\text{inex}}(\omega_0)$ and $\forall \delta\phi^0 \in V_{\text{inex}}^{\phi^0}(\omega_0)$</p> $\int_{\omega_0} \text{Tr}(m_t^0 \delta K_t^0) d\omega_0 = \int_{\omega_0} \bar{p} \delta U^0 d\omega_0$	$K_t^0 = \bar{C} - C_0$ <p>ϕ^0 is inextensional</p>
$\varepsilon^{n \geq 4}$	$h_0 \varepsilon^{n-2}$	<p>linear membrane model if L.I.S.</p> <p>$U^0 \in V(\omega_0)$ and $\forall \delta U^0 \in V(\omega_0)$</p> $\int_{\omega_0} \text{Tr}(n_t^0 \delta\Delta_t^0) = \int_{\omega_0} \bar{p} \delta U^0 d\omega_0$	$2\Delta_t^0 = \frac{\hat{\partial} U^0}{\partial p_0} + \frac{\overline{\hat{\partial} U^0}}{\partial p_0}$
$\varepsilon^{n \geq 4}$	$h_0 \varepsilon^{n-4}$	<p>linear pure bending model if N.L.I.S.</p> <p>$U^0 \in V_{\text{inex}}(\omega_0)$ and $\forall \delta U^0 \in V_{\text{inex}}(\omega_0)$</p> $\int_{\omega_0} \text{Tr}(m_t^0 \delta K_t^0) d\omega_0 = \int_{\omega_0} \bar{p} \delta U^0 d\omega_0$	$2K_t^0 = \frac{\hat{\partial} \Theta^0}{\partial p_0} + \frac{\overline{\hat{\partial} \Theta^0}}{\partial p_0} + \frac{\hat{\partial} U^0}{\partial p_0} C_0$ $+ C_0 \frac{\overline{\hat{\partial} U^0}}{\partial p_0}$ <p>U^0 is linearly inextensional</p>

Table 2. Inhibited shells in the nonlinear range.

\mathcal{T}	U_r	Shell model	Δ_t, K_t
ε	L_0	<p>nonlinear membrane model</p> <p>$\phi^0 \in Q(\omega_0)$ and $\forall \delta\phi^0 \in V(\omega_0)$</p> $\int_{\omega_0} \text{Tr}(n_i^0 \delta\Delta_t^0) d\omega_0 = \int_{\omega_0} \bar{p} \delta\phi^0 d\omega_0$	$2\Delta_t^0 = \frac{\overline{\partial\phi^0}}{\partial p_0} \frac{\partial\phi^0}{\partial p_0} - I_0$
ε^2	h_0	<p>linear membrane model</p> <p>$U^0 \in V(\omega_0)$ and $\forall \delta U^0 \in V(\omega_0)$</p> $\int_{\omega_0} \text{Tr}(n_i^0 \delta\Delta_t^0) d\omega_0 = \int_{\omega_0} \bar{p} \delta U^0 d\omega_0$	$2\Delta_t^0 = \frac{\overline{\partial U^0}}{\partial p_0} + \frac{\hat{\partial} U^0}{\partial p_0}$
$\varepsilon^{n \geq 3}$	$h_0 \varepsilon^{n-2}$	<p>linear membrane model if L.I.S.</p>	...
ε^3	h_0	<p>second coupling model if N.L.I.S</p> <p>$(U^0, U^1) \in V_{\text{inex}}(\omega_0) \times V(\omega_0)$</p> $\int_{\omega_0} \text{Tr}(n_i^1 \delta\Delta_t^1 + m_i^0 \delta K_t^0) d\omega_0 =$ $\int_{\omega_0} (\bar{p} \delta U^1 - \text{Tr}(C_0) \bar{M} \delta U^0 + \bar{M} \delta \Theta^0) d\omega_0$ <p>$\forall (\delta U^0, \delta U^1) \in V_{\text{inex}}(\omega_0) \times V(\omega_0)$</p>	$2\Delta_t^1 = \frac{\overline{\partial U^1}}{\partial \theta_0} + \frac{\hat{\partial} U^1}{\partial p_0} + \frac{\overline{\partial U^0}}{\partial p_0} \frac{\partial U^0}{\partial p_0}$ $K_t^0 = \frac{\overline{\partial \Theta^0}}{\partial p_0} + \frac{\hat{\partial} \Theta^0}{\partial p_0} + \frac{\hat{\partial} U^0}{\partial p_0} C_0$ $+ C_0 \frac{\overline{\partial U^0}}{\partial p_0}$ <p>U^0 is linearly inextensional</p>
$\varepsilon^{n \geq 4}$	$h_0 \varepsilon^{n-4}$	<p>linear pure bending model if N.L.I.S.</p> <p>$U^0 \in V_{\text{inex}}(\omega_0)$ and $\forall \delta U^0 \in V_{\text{inex}}(\omega_0)$</p> $\int_{\omega_0} \text{Tr}(m_i^0 \delta K_t^0) d\omega_0 = \int_{\omega_0} \bar{p} \delta U^0 d\omega_0$	$K_t^0 = \frac{\overline{\partial \Theta^0}}{\partial p_0} + \frac{\hat{\partial} \Theta^0}{\partial p_0} + \frac{\hat{\partial} U^0}{\partial p_0} C_0$ $+ C_0 \frac{\overline{\partial U^0}}{\partial p_0}$ <p>U^0 is linearly inextensional</p>

We recall the definitions of the admissible spaces of mapping and displacements:

$$V(\omega_0) = \{U : \omega_0 \rightarrow \mathbb{R}^3, \text{ "smooth", } U = 0 \text{ on } \gamma_0^1\},$$

$$Q(\omega_0) = \{\phi : \omega_0 \rightarrow \mathbb{R}^3, \text{ "smooth", } \phi = i_{\omega_0} \text{ on } \gamma_0^1\},$$

$$V_{\text{inex}}(\omega_0) = \left\{U \in V(\omega_0), \frac{\hat{\partial}U}{\partial p_0} + \overline{\frac{\hat{\partial}U}{\partial p_0}} = 0 \text{ in } \omega_0 \text{ and } \overline{\frac{\partial U}{\partial p_0}} N_0 = 0 \text{ on } \gamma_0^1\right\},$$

$$V_{\text{inex}}^{\phi^0}(\omega_0) = \left\{U \in V(\omega_0), \frac{\overline{\partial \phi^0}}{\partial p_0} \frac{\partial U}{\partial p_0} + \overline{\frac{\partial U}{\partial p_0}} \frac{\partial \phi^0}{\partial p_0} = 0 \text{ in } \omega_0\right\},$$

$$Q_{\text{inex}}(\omega_0) = \left\{\phi \in I_{\text{inex}}(\omega_0), \overline{\frac{\partial \phi}{\partial p_0}} N_0 = 0 \text{ on } \gamma_0^1\right\},$$

where the space of inextensional mappings $I_{\text{inex}}(\omega_0)$ is defined as follows :

$$I_{\text{inex}}(\omega_0) = \left\{\phi : \omega_0 \rightarrow \mathbb{R}^3, \text{ "smooth", } \overline{\frac{\partial \phi}{\partial p_0}} \frac{\partial \phi}{\partial p_0} = I_0 \text{ in } \omega_0, \phi = i_{\omega_0} \text{ on } \gamma_0^1\right\}.$$

With the approach developed in this paper, the obtained asymptotic shell models, even the linear ones, have been deduced from the nonlinear three-dimensional elasticity. This enables us to specify their domain of validity thanks to the dimensionless numbers naturally introduced. In particular, we proved in this second part that the linear membrane model (respectively the pure bending one) is valid for a linearly inhibited (respectively for a linearly non-inhibited) shell subjected to low force levels of $\varepsilon^{n \geq 4}$ order. We find again the classical results [14][21][22] obtained here from the *nonlinear elasticity*. This proves that for sufficiently low force levels, the membrane strain becomes linear and only the geometric rigidity in the linear range must be taken into account. However, the link between the linear and the nonlinear inextensional displacements is still to study.

On the other hand, in the literature only two nonlinear shell models are obtained by asymptotic expansion of three-dimensional elasticity: the nonlinear membrane model [13] and the pure bending one [11]. Contrary to these works, the systematic study of all the force levels has put here in a prominent position two other nonlinear shell models which couple the membrane and the bending effects. These models are different from the usual models of SANDERS [23], NAGHDI [16], SCHMIDT [1], PIETRASZKIEWICZ [18]. This constitutes the constructive character of the approach presented.

References

1. R. SCHMIDT, *A current trend in shell theory: constrained geometrically nonlinear Kirchhoff-Love type theories based on polar decomposition of strains and rotations*, Computers and Structures, **20** 1-3, 265-275, 1985.
2. D. CHOÏ, *Sur la rigidité géométrique des surfaces. Application à la théorie des coques élastiques minces*, Thèse, Université de Paris VI, 1995.
3. P. G. CIARLET and D. COUTAND, *Un théorème d'existence pour une coque non linéairement élastique "en flexion"*, C. R. Acad. Sci., Paris, t. 326, série I, 903-907, 1998.
4. P. DESTUYNDER, *Sur une justification des modèles de plaques et de coques par les méthodes asymptotiques*, Thèse d'Etat, Université de Pierre et Marie Curie, Paris, 1980.
5. P. DESTUYNDER, *A classification of thin shell theories*, Acta Applicandae Mathematicae, **4**, 15-63, 1985.
6. K. ELAMRI, *Une classification des modèles asymptotiques de coques déduite de l'élasticité tridimensionnelle non linéaire*, Thèse, Université de Poitiers, 1998.
7. I. M. N. FIGUEIREDO, *Modèles de coques élastiques non linéaires: méthode asymptotique et existence des solutions*, Thèse, Université de Pierre et Marie Curie, Paris, 1989.
8. G. GEYMONAT and E. SANCHEZ-PALENCIA, *On the rigidity of certain surfaces with folds and applications to shell theory*, Arch. Rational Mech. Anal., **129**, 11-45, 1995.
9. A. L. GOL'DENVEIZER, *Theory of elastic thin shells*, Pergamon Press, 1961.
10. A. HAMDOUNI and O. MILLET, *Classification of thin shell models deduced from the nonlinear three-dimensional elasticity. Part I: the shallow shells*, Arch. of Mech, 135-175, 2003.
11. V. LODS and B. MIARA, *Nonlinearly elastic shell models : A formal asymptotic approach. II. The flexural model*, Arch. Ration. Mech. Anal., **142**, 4, 355-374, 1998.
12. A. E. H. LOVE, *A Treatise on the mathematical theory of elasticity*, Cambridge University Press, 1927.
13. B. MIARA, *Analyse asymptotique des coques membranaires non linéairement élastiques*, C. R. Acad. Sci., Paris, t. 318, série I, 689-694, 1994.
14. B. MIARA and E. SANCHEZ-PALENCIA, *Asymptotic analysis of linearly elastic shells*, Asymptotic Analysis, 41-54, 1996.
15. O. MILLET, *Contribution à l'analyse asymptotique en théorie des plaques et des coques*, Thèse, Université de Poitiers, juillet 1997.
16. P. M. NAGHDI, *The theory of shells and plates*, Flügge's Handbuch der Physik, Vol. VIa/2, C. TRUESDELL [Ed.], Springer-Verlag, 425-640, 1972.
17. V. V. NOVOZHILOV, *The theory of thin shells*, Walters Noordhoff Publ., Groningen, 1959.
18. W. PIETRASZKIEWICZ, *Finite rotations in shells*, [in:] Theory of Shells, North Holland Publishing Company, 445-471, 1980.
19. E. SANCHEZ-PALENCIA, *Statique et dynamique des coques minces, I - Cas de flexion pure non inhibée*, C. R. Acad. Sci., Paris, t. 309, série I, 411-417, 1989.

20. E. SANCHEZ-PALENCIA, *Statique et dynamique des coques minces, II - Cas de flexion pure inhibée - Approximation membranaire*, C. R. Acad. Sci., Paris, t. 309, série I, 531–537, 1989.
21. E. SANCHEZ-PALENCIA, *Passage à la limite de l'élasticité tridimensionnelle à la théorie asymptotique des coques minces*, C. R. Acad. Sci., Paris, t. 311, série II b, 909–916, 1990.
22. J. SANCHEZ-HUBERT and E. SANCHEZ-PALENCIA, *Coques élastiques minces. Propriétés asymptotiques*, Masson 1997.
23. J. L. SANDERS, *Nonlinear theories for thin shells*, Q. Appl. Math., **21**, 21–36, 1963.
24. M. L. SZWABOWICZ, *Deformable surfaces and almost inextensional deflexions of thin shells*, Habilitation, Gdańsk 1999.
25. R. VALID, *The nonlinear theory of shells through variational principles*, John Wiley and Sons Ltd, 1995.
26. I. N. VEKUA, *Generalized analytic functions*, Pergamon, 1962.

Received February 1, 2002; revised version July 25, 2002.
