

ASSESSMENT OF LEFT VENTRICLE PHANTOM WALL COMPRESSIBILITY BY ULTRASOUND AND COMPUTED TOMOGRAPHY METHODS

ZBIGNIEW TRAWIŃSKI¹⁾, JANUSZ WÓJCIK¹⁾, ANDRZEJ NOWICKI¹⁾,
ANDRZEJ BALCERZAK¹⁾, ROBERT OLSZEWSKI²⁾,
EMILIA FRANKOWSKA³⁾, ARKADIUSZ ZEGADŁO³⁾,
PAWEŁ RYDZYŃSKI³⁾

⁽¹⁾ Institute of Fundamental Technological Research, Polish Academy of Sciences
Adolfa Pawińskiego 5b, 02-106 Warsaw, Poland

⁽²⁾ Department of Cardiology & Internal Medicine, Military Medical Institute
Szaserów 128, 04-141 Warsaw, Poland

⁽³⁾ Radiology Medicine Department, Military Medical Institute
Szaserów 128, 04-141 Warsaw, Poland
ztraw@ippt.pan.pl

The present work concerns the sonographic model of the left ventricle (LV) examined in the Computed Tomography (CT) environment and compare radial strain calculations obtained by two different techniques: the speckle tracking ultrasonography and the Multislices Computed Tomography (MSCT). The Left Ventricular (LV) phantom was fabricated from 10% solution of the poly(vinyl alcohol) (PVA). Our model of the LV was driven by the computer-controlled hydraulic piston Super-Pump (Vivitro Inc., Canada) with adjustable fluid volumes. The stroke volume was set at of 24ml. The fluid pressure was changed within range of 0-60 mmHg, and the pulse rate was of 60 cycles/per minute. The relationships between computer controlled left ventricular wall deformations and its visualizations of the echocardiographic and CT imaging, both in the normal and pathological conditions were examined. The difference of assessment the Radial Strain between two methods was not exceeding 1.1%.

INTRODUCTION

One of the most common applications of echocardiography in clinical practice is assessment of the left ventricle (LV) phantom. The cases in which it is difficult to expose endocardial boundaries constitute a huge challenge and despite tremendous technological progress for 10-20% of sick and especially obese people the optimal image cannot be

obtained. The two promising tools used during the last decade have been the techniques acquiring scattered echoes energy from the unprocessed (RF) signals (integrated backscatter) and Doppler assessment of tissue movement using the DTI [1], [2]. However the first technique suffers the lack of a uniform algorithm of data acquisition and processing. Different parameters of DTI and deformation have been examined in order to assess the LV function. But both these techniques have not caused remarkable progress. From among different techniques used to examine elasticity of tissues, the so-called *speckle tracking* modality deserves special attention.

Ryan et al. [3] worked out the visualization method of intravascular elasticity of artery walls using rotating high frequency (42 MHz) ultrasound transducer and applying *speckle tracking* technique. However the analysis of artery wall movement was not possible in real time but only after completing the RF signals acquisition. The authors applied the blood vessel phantom made of gelatin and subjected it to intravascular change of pressure from 100 to 120 mmHg and next the RF echoes were correlated between successive frames. Elastic soft “tissue” properties were measured on specially prepared models in the form of elastic pipes made of different materials with echogenicity similar to that of the human tissue. At first the mixture of agar and gelatin [4], [5] or polyvinyl alcohol gel [6]) were used to fabricate tissue phantoms. These phantoms were however not resistant to applied pressure changes because they were ruptured when radial deformations exceeded 5%.

For almost 7 years the *speckle tracking* modality, which has been widely advertised by the majority of echocardiological equipment manufacturers, however without the thorough discussion of the algorithms and mathematical expressions applied. Lack of important definitions of measured parameters leads to impossibility of conducting comparative studies using ultrasound scanners of different manufacturers. This problem was noticed only by doctors carrying out examinations in clinics already possessing different US scanners.

The support of the *speckle tracking* technique is even more inexplicable because it was proven in the work of Tournoux et al. [7] that this method is two times worse than the method of tissue contours tracking of ultrasound image.

1. SPECKLE TRACKING

Despite the fast development of new scanning machines and new algorithms, the objective method of verification of the results (especially obtained using different scanners) is missing. The basis of the concept of speckle tracking algorithm is a relationship between displacement of heterogeneities of the tissue and the displacement of the resulting speckles in the US image. Both models are integrated, especially in the context of the description of the deformation of the phantom wall, taking into account different distribution of local changes in the density distribution of the phantom material, resulting in the speckles pattern of the ultrasonic image, (Fig.1).

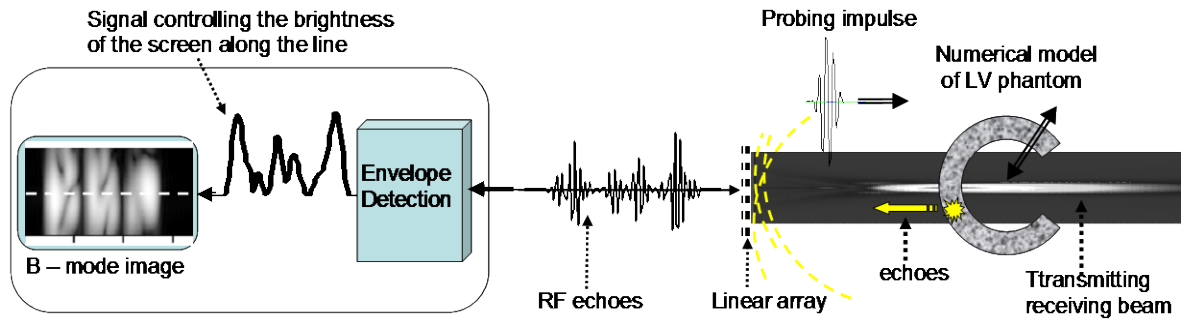

Fig.1. Acoustic track diagram of the LV phantom.

2. ULTRASOUND MODEL OF THE LEFT VENTRICLE

The Left Ventricular (LV) phantom was fabricated from a 10% solution of poly(vinyl alcohol) (PVA). The material used to fabricate the model was suitable for processing. Material used to manufacture the phantom is a 10% (mass) aqueous solution of PVA (molecular weight 89000-98000, 99+% hydrolyzed, Sigma-Aldrich, St. Louis, MO, USA).

The solution was prepared by dissolving a weighted amount of PVA in water at a temperature of 80-85°C. A magnetic stirrer mixed the solution until PVA became dissolved. In the next step, the solution was cooled to room temperature and placed in a vacuum for one hour to remove air bubbles suspended in the solution. After that, the solution was poured into a mold made from polymethyl methacrylate. Then the mold was placed in a freezer at $-25 \pm 0.5^\circ\text{C}$ for 35 hours and then thawed for approximately 40 hours to room temperature.

This material is durable and does not require an additional process of venting before each experiment. Our model of the LV was driven by a computer-controlled hydraulic piston Super-Pump (Vivitro Inc., Canada) with adjustable fluid volumes and with various loads. The *Strain* examinations were performed for an ultrasonic beam angle of 90° . The measurements were conducted for a heart rate (HR) of 60 cycles per minute.

LV phantoms are presented in Fig. 2. The local hardness of the phantom wall, mimicking the pathological changes, was obtained by a drying process.

a)



b)



Fig. 2. The LV phantoms: a) – normal, b) with stiffened wall imitating the myocardial infarction.

During the cycle of the pump, the Stroke Volume (SV) of water was pumped into the LV phantom and returned to the pump, resulting in changing the inner and outer diameters of the phantom.

3. METHODS AND RESULTS

The percentage change of geometry (length, thickness) of examined targets (compared with its initial size) is called the *Lagrangian strain*. The *strain* and the *strain rate* (SR) imaging enable to take segmental measurement of the myocardium strain for the assessment of its local and global functioning. *Strain* describes the relative deformation. SR represents the changes in strain per time unit. The radial strain (*RS*) is given by maximum in time of the relative change of the internal LV phantom radius,

$$RS \equiv \frac{\Delta R}{R_{Dias}} = \frac{R_{Dias} - R_{Syst}}{R_{Dias}} \quad (1)$$

where: $R_{Dias} = R_1(t = \text{diastolic phase})$, $R_{Syst} = R_1(t = \text{systolic phase})$, $R_1(t)$ is an inner radius of the cylinder.

Our new phantom of the left ventricle allows a fully controlled testing of algorithms tracking the dispersion of acoustic markers, as well as improving the existing algorithms or supporting the construction of new ones.

A. *Ultrasound Examination:*

The repeatability of the parameters measured by using the ultrasound scanners made by different manufacturers is a major problem. In this work the new method for assessment of the quantitative speckles tracking method is proposed.

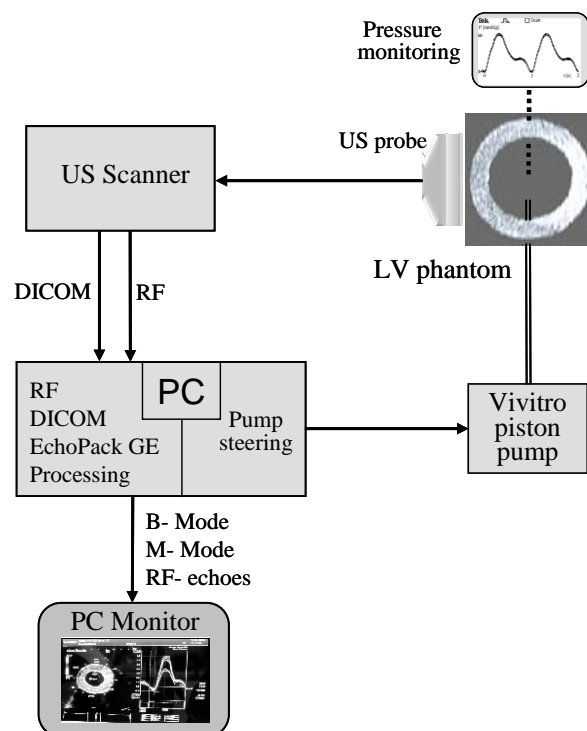

Fig. 3. Setup for elastic properties measurements of the LV model by ultrasound.

The setup for elastic properties measurements of the LV phantom is shown in Fig. 3. It consists of the LV model immersed in cylindrical tank filled with water, the hydraulic pump, the ultrasound scanner, the hydraulic pump controller, the pressure measurement system of water inside the LV model and the iMac workstation. The stroke volume was set of 24 ml. The fluid pressure was changed from 0 to 300mmHg, at the

frequency of 40 - 120 cycles per minute. The results showed that both, radial strain, radial strain rate, circumferential strain and circumferential strain rate were independent on the insonifying angle, and pulse rate.

The difference between positions of wall surface in diastole and systole is used to calculate our Radial Strain (RS) Eq. 1.

B. CT Examination:

Modern cardiac CT scanning is a fast, noninvasive method with excellent temporal resolution that defines image details. Implementing new dose reduction protocols ensures the dose lower than during invasive coronary angiography. Cardiac functional analysis requires data from entire cardiac cycle. 64-detector scanner (Discovery CT 750 HD, GE Healthcare, 2012) covers 4cm of cranio-caudal distance every heartbeat. Spatial resolution of the scans is 18,2lp/cm. The data obtained from several cardiac cycles is used to generate axial images as well as three-dimensional and multiplanar reconstructions. CT is vulnerable to artifacts from arrhythmia, ectopic beats and fast heart rate. Recent advantages in CT scanners and image processing help to deliver sufficient efficacy in image interpretation in technically difficult patients. The comparison of both techniques, ultrasound scanning and CT was performed using Vivid S5 (GE Healthcare) with 3.5MHz and CT 750 HD 64-slice (GE Healthcare, 2012) machines. In both measurement sessions the PR = 60cycles/minute and the SV = 24ml.



Fig. 4. CT setup for elastic properties measurements of the LV model.

For the purpose of the CT scanning LV model was filled with the diluted iodine contrast agent (20% solution of the product Iodixanol 320mgI/ml Visipaque 320, GE Healthcare). Retrospective the ECG-gated MSCT acquisition Discovery CT 750 HD 64-slice (GE Healthcare, 2012) was performed with 0.6 mm slice thickness. The data were reconstructed every 10% of the R-to-R interval of the ECG signal produced by the Vivitro SuperPump control device. The cross-section LV phantom images were obtained using myocardium analysis protocol with manual settings of the valve and the apex.

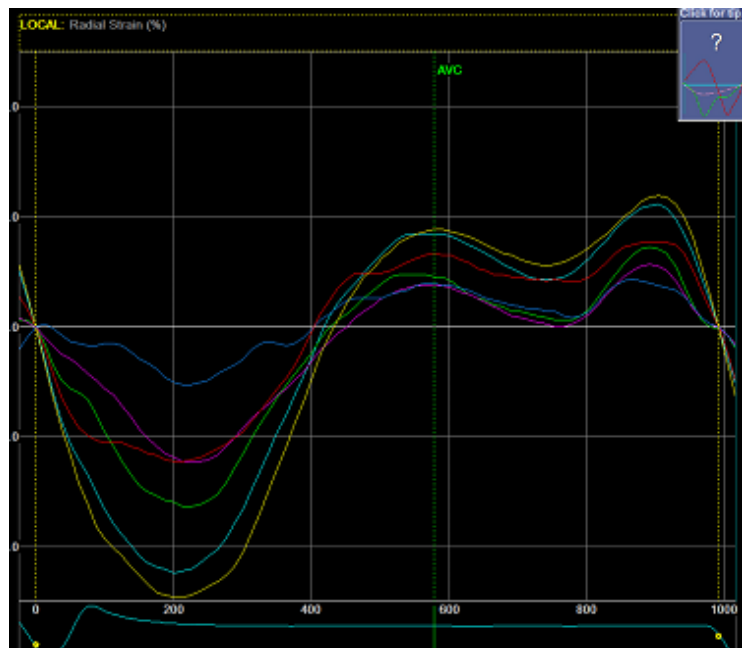

Fig. 5. Radial strain analysis using the EchoPack PC GE software.

Under the EchoPack PC software environment, LV model plane was automatically segmented into six segments. The internal vertical diameter (yellow and violet lines) was taken into account in the Radial Strain analysis.

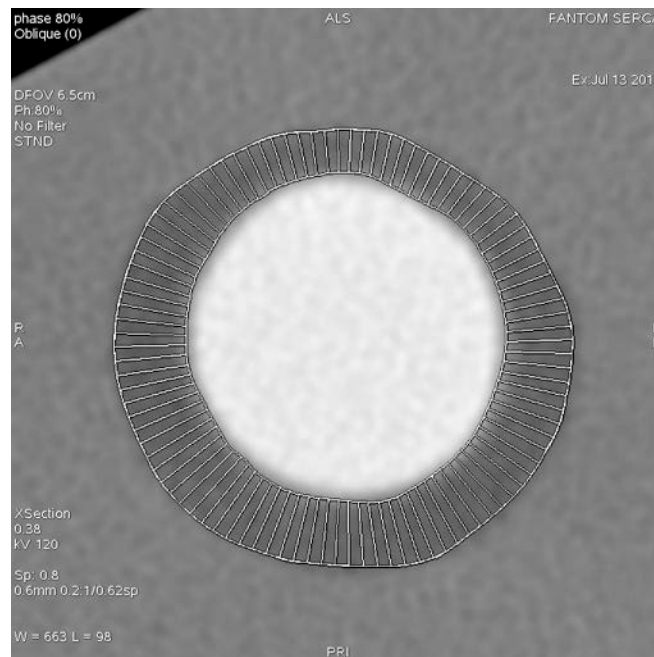

Fig. 6. CT cross-section image of the LV phantom with the contrast agent.

The value of speckle tracking based radial strain $RS_{st} = 24.6\%$. The Radial Strain obtained by the MSCT imaging was $RS_{CT} = 23.5\%$.

4. DISCUSSION AND CONCLUSIONS

Recent studies has shown that MSCT is effective in quantitative analysis of LV strain [8] and [9], MSCT imaging provides excellent isotropic resolution, decreases partial volume effect and motion artifacts what makes it appropriate reference method for echocardiographic measurements. The study indicates the usefulness of the ultrasonographic LV model in the CT technique. The results showed the very good agreement, at the level of 1.1%, in the Radial Strain assessment between speckle tracking technique and the multislice CT examination. The presented ultrasonographic LV phantom may serve to analyze left ventricle wall strains in physiological as well as pathological conditions [10].

The CT has potential to serve, as reference method, in conducting comparative studies using ultrasound scanners of different manufactures.

ACKNOWLEDGMENT

This work was supported in the part by the National Science Centre (project N N518 292340).

REFERENCES

- [1] A. Nowicki, R. Olszewski, J. Etienne, P. Karłowicz, J. Adamus, The Assessment of Wall Velocity Gradient Imaging using Test-Phantom, *Ultrasound in Medicine and Biology*, Vol. 22, 9, pp. 1255-1260, 1996.
- [2] A. Lange, P. Typha A. Nowicki, R. Olszewski, T. Anderson, J. Adamus, G. Sutherland, A. Keith, Three-dimensional echocardiographic evolution of left ventricular volume: Comparison of Doppler myocardial imaging and standard gray-scale imaging with cineventriculography – an in vitro and in vivo study, *American Heart Journal*, Vol. 135, 6, pp. 970-979, 1998.
- [3] L. K. Ryan, G. R. Lockwood, T. S. Bloomfield, F. S. Foster, Speckle tracking in High frequency ultrasound images with application to intravascular imaging, *Proceedings IEEE Ultrasonics Symposium*, pp. 889-892, 1993.
- [4] C. L. De Korte, I. A. Céspedes, F. W. Van der Steen, C. T. Lancee, Intravascular elasticity imaging using ultrasound: Feasibility studies in phantoms, *Ultrasound Med. & Biol.*, Vol. 23, pp. 735-746, 1997.
- [5] T. J. Hall, M. Insana, M. F. Bilgen, T. A. Krouskop, Phantom materials for elastography, *IEEE Trans. Ultrason. Ferroelectr Freq. Contr.*, Vol. 44, pp. 1355-1364, 1997.
- [6] E. Brusseau, J. Fromageau, G. Finet, P. Delachartre, P. Vray, Axial strain of intravascular date: results on polivinyl alcohool cryogel phantoms and carotid artery, *Ultrasound Med. & Biol.*, Vol. 27, pp. 553-1642, 2001.
- [7] F. Tournoux, C. Chan, M. D. Handshumacher, B. Salgo and S. Manzke, S. Settlemier, J. L. Guerrero, C. Cury, A. E. Weyman, M. H. Picard, Estimation of radial strain and rotation using a new algoritm based on speckle tracking, *J. Am. Soc. Echocardiogr.*, Vol. 21, pp. 1168-1179, 2008.
- [8] R. Olszewski, Z. Trawiński, J. Wójcik, A. Nowicki, Mathematical and Ultrasonographic Model of the Left Ventricle: in Vitro Studies, *Archives of Acoustics*, Vol. 37, 4, pp. 583-595, 2012.
- [9] S.J. Buss, F. Schulz, D. Mereles, W. Hosch, C. Galuschky, G. Schummers, D. Stapf, Hofmann N, Giannitsis E, Hardt SE, Kauczor HU, Katus HA, Korosoglou G.

- Quantitative analysis of left ventricular strain using cardiac computed tomography, *Eur J Radiol.*, [Epub ahead of print], Dec 7, 2013.
- [10] Z. Trawiński, J. Wójcik, A. Nowicki, R. Olszewski, Dynamic Ultrasonic Model of Left Ventricle, *Hydroacoustics*, Vol. 16, pp. 231-236, 2013.